

MODEL SB-650 Frequency Display

# HEATHKIT<sup>®</sup>

## ASSEMBLY MANUAL

Model SB-650 Frequency Display

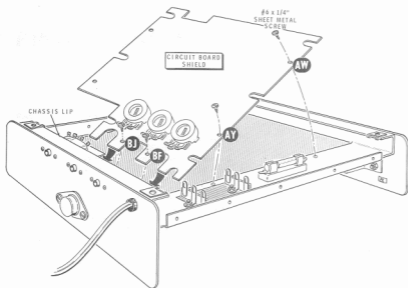


PRICE \$2.00

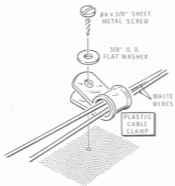


Copyright ©1972  
Heath Company  
All rights reserved

695-1401-01



**Detail 4-1B**



**Detail 4-1C**

LOGIC LEVEL VOLTAGES

	MINIMUM	MAXIMUM
INPUT-HIGH	2V	
INPUT-LOW		0.5V
OUTPUT-HIGH	2.4V	
OUTPUT-LOW		0.4V

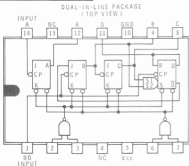
BCD COUNT SEQUENCE  
(SEE NOTE)

COUNT	OUTPUT			
	D	C	B	A
0	0	0	0	0
1	0	0	0	1
2	0	0	1	0
3	0	0	1	1
4	0	1	0	0
5	0	1	0	1
6	0	1	1	0
7	0	1	1	1
8	1	0	0	0
9	1	0	0	1

NOTE: OUTPUT A CONNECTED TO  
INPUT B0 FOR BCD COUNT.

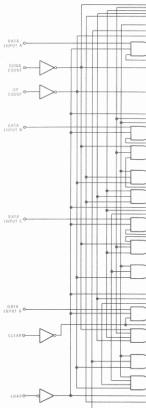
OUTPUT D IS 1/10 OF INPUT  
A  $1 \rightarrow 101$ .

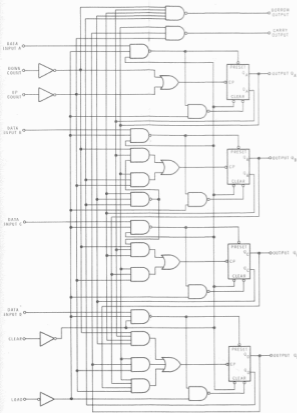
OUTPUT A IS 1/2 OF INPUT  
A  $1 \rightarrow 21$ .



1C4, 5, 6, 7, 8, 9  
SN7490N

FIGURE H





DUAL IN-LINE PACKAGE (TOP VIEW)

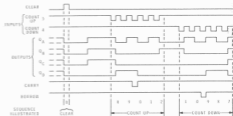


LOGIC LEVEL VOLTAGES

	MINIMUM	MAXIMUM
INPUT-HIGH	2V	5.0V
INPUT-LOW		0.8V
OUTPUT-HIGH	2.0V	
OUTPUT-LOW		0.4V

ILLUSTRATED BELOW IS THE FOLLOWING SEQUENCE:

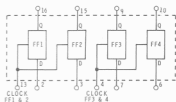
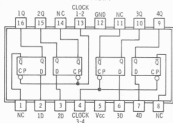
1. CLEAR OUTPUTS TO ZERO.
2. COUNT UP TO (HUNT) UNTIL CARRY ZERO, ONE AND TWO.
3. COUNT DOWN TO ONE, ZERO, ERROR, ONE, TWO, AND THREE.



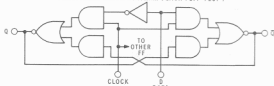
NOTES: A. CLEAR OVERRIDES COUNT INPUT.  
 B. WHEN COUNTING UP, COUNT-DOWN INPUT MUST BE HIGH.  
 WHEN COUNTING DOWN, COUNT-UP INPUT MUST BE HIGH.

IC12, 13, 14, 15, 16, 17  
 SN74192N

UP-DOWN COUNTER  
 FIGURE J

DUAL-IN-LINE PACKAGE  
(TOP VIEW)

FUNCTIONAL BLOCK DIAGRAM (EACH FLIP-FLOP)



EACH STORAGE REGISTER

TRUTH TABLE (EACH FLIP-FLOP)	
$t_n$	$t_n+1$
0	Q
1	1
0	0

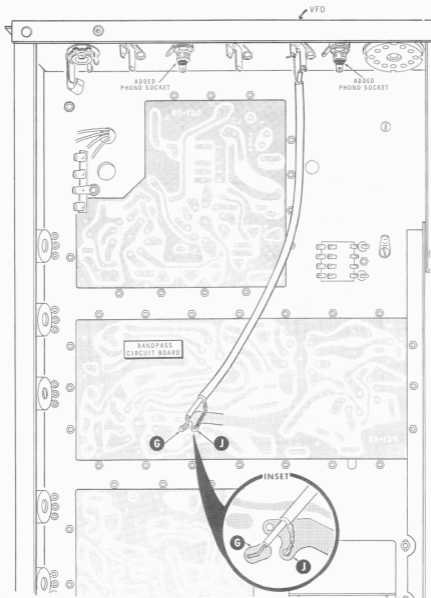
- NOTES: 1.  $t_n$  = BIT TIME BEFORE CLOCK  
NEGATIVE-GOING TRANSITION.  
2.  $t_n+1$  = BIT TIME AFTER CLOCK  
NEGATIVE-GOING TRANSITION.

LOGIC LEVEL VOLTAGES

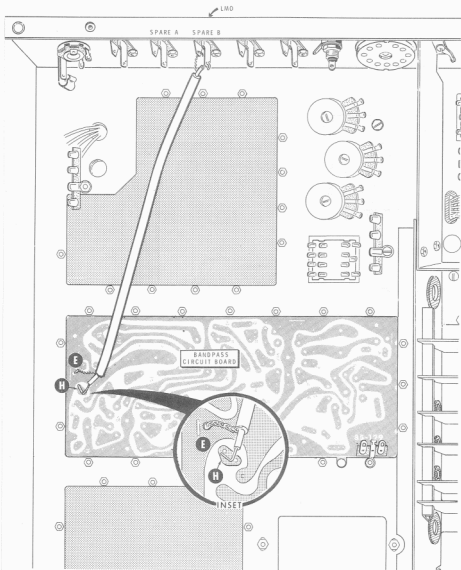
	MINIMUM	MAXIMUM
INPUT-HIGH	2V	
INPUT-LOW		0.8V
OUTPUT-HIGH	2.4V	
OUTPUT-LOW		0.4V

IC18, 19, 20, 21, 22, 23  
SN7475N

Figure K



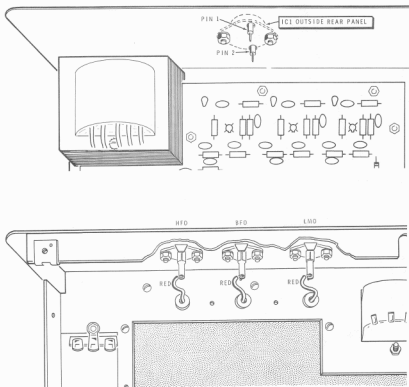
**FIGURE 3-10**  
(HW-SERIES)



**FIGURE 3-9**

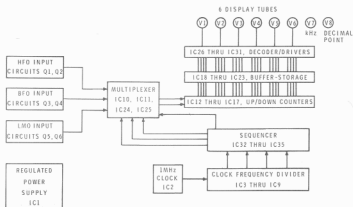
(SB-SERIES)

LMO

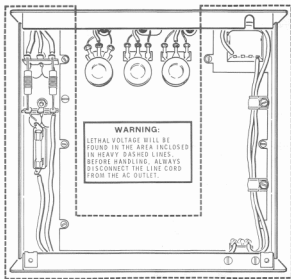


**FIGURE 4-1**





**BLOCK DIAGRAM**  
**FIGURE 6-1**



**HIGH VOLTAGE AREAS**

Assembly  
and  
Operation  
of the



## FREQUENCY DISPLAY

MODEL SB-650



HEATH COMPANY  
BENTON HARBOR, MICHIGAN 49022

## TABLE OF CONTENTS

INTRODUCTION . . . . .	3
PARTS LIST . . . . .	5
STEP-BY-STEP ASSEMBLY . . . . .	9
Circuit Board Assembly . . . . .	10
Chassis Assembly . . . . .	
Chassis Parts Mounting . . . . .	21
Circuit Board Mounting . . . . .	23
Panel Preparation and Mounting . . . . .	24
Chassis Bottom Wiring . . . . .	25
Transformer Primary Wiring . . . . .	27
Chassis Top Wiring . . . . .	29
Cable Preparation . . . . .	30
INSTALLATION . . . . .	31
Transceivers . . . . .	32
Receivers . . . . .	36
INITIAL TESTS . . . . .	39
CIRCUIT BOARD SHIELD INSTALLATION . . . . .	41
CALIBRATION . . . . .	43
FINAL ASSEMBLY . . . . .	45
OPERATION . . . . .	47
IN CASE OF DIFFICULTY . . . . .	48
General Troubleshooting Information . . . . .	48
Troubleshooting Chart . . . . .	50
Voltage Checks . . . . .	52
Important Wave Shapes . . . . .	54
SPECIFICATIONS . . . . .	65
CIRCUIT DESCRIPTION . . . . .	67
SCHEMATIC APPENDIX . . . . .	75
CHASSIS PHOTOGRAPHS . . . . .	81
CIRCUIT BOARD X-RAY VIEWS . . . . .	82
SCHEMATIC . . . (fold-out from page) . . . . .	85
Warranty . . . . .	Inside front cover
Customer Service . . . . .	.Inside rear cover

# INTRODUCTION

The Heathkit Model SB-650 Frequency Display is designed to operate with Heath amateur receivers and five-band transceivers of the SB and HW series operating in the 3 to 30 MHz range. It calculates the received frequency to 1/10 kHz and displays the frequency on six display tubes. The only operating control is a front panel rocker switch which turns the instrument on and off.

A digital up/down counter is used to calculate the operating frequency from three oscillators — the high frequency oscillator, the linear master oscillator, and the beat frequency oscillator. However, it is not used on the 15 MHz (WWV) band of the SB-301 receiver, nor on AM signals, because outputs for all three oscillator signals are not available on the rear panels.

Because the Frequency Display is direct reading, it eliminates the problem of adding together frequencies from a switch position and two dial readings. Its superior accuracy produces the precise location of your position in the band, and its brightly illuminated display provides frequency monitoring 100% of the time.

The test equipment required for the Initial Tests and alignment of this Frequency Display is a voltmeter capable of measuring .1 volt ac and dc. A general coverage receiver may be desirable for calibration of the clock (crystal) oscillator.

Read the "Kit Builders Guide" for complete information on unpacking, parts identification, tools, wiring, soldering, and step-by-step assembly procedure.

# PARTS LIST

This "Parts List" contains all of the parts used in the assembly of the kit. Some parts may be packaged in envelopes with the part number of the contents printed on the outside. Except for the initial parts check, retain these parts in their envelopes until they are called for in the assembly steps. When more than one number is on a package, disregard all but the part number listed in the "Parts List."

Check each part against the following list. The key numbers correspond to the numbers on the Parts Pictorial (fold-out from Page 9).

To order a replacement part, use the Parts Order Form furnished with this kit. If a Parts Order Form is not available, refer to "Replacement Parts" inside the rear cover of the Manual.

KEY PART No.	PARTS No.	DESCRIPTION	PRICE Each
-----------------	--------------	-------------	---------------

## RESISTORS

NOTE: The following resistors are 10%, 1/2-watt, unless otherwise indicated.

A1	1-62	1	51 $\Omega$ , 5% (green-brown-black-gold)	.10
A1	1-3	6	100 $\Omega$ (brown-black-brown)	.10
A1	1-66	1	150 $\Omega$ (brown-green-brown)	.10
A1	1-137	1	200 $\Omega$ , 5% (red-black-brown-gold)	.10
A1	1-42	3	270 $\Omega$ (red-violet-brown)	.10
A1	1-4	1	330 $\Omega$ (orange-orange-brown)	.10
A1	1-7	2	680 $\Omega$ (blue-gray-brown)	.10
A1	1-9	3	1000 $\Omega$ (brown-black-red)	.10
A1	1-20	6	10 k $\Omega$ (brown-black-orange)	.10
A1	1-24	1	33 k $\Omega$ (orange-orange-orange)	.10
A1	1-25	1	47 k $\Omega$ (yellow-violet-orange)	.10
A1	1-26	9	100 k $\Omega$ (brown-black-yellow)	.10
A1	1-27	1	150 k $\Omega$ (brown-green-yellow)	.10
A1	1-29	3	220 k $\Omega$ (red-red-yellow)	.10

KEY PART No.	PARTS No.	DESCRIPTION	PRICE Each
-----------------	--------------	-------------	---------------

## Precision Resistors, 1%

A2	2-239	1	1900 $\Omega$	.25
A2	2-33	1	6838 $\Omega$	.25

## CONTROL

A3	10-52	3	2000 $\Omega$ (2 k)	.35
----	-------	---	---------------------	-----

## CAPACITORS

### Disc

A4	21-32	6	47 pF	.10
A4	21-22	1	220 pF	.10
A4	21-140	11	.001 $\mu$ F	.10
A4	21-71	4	.001 $\mu$ F (1.4 KV)	.10
A4	21-36	1	.002 $\mu$ F	.10
A4	21-143	1	.05 $\mu$ F	.20
A4	21-95	5	.1 $\mu$ F	.15

### Other

A5	25-248	1	100 $\mu$ F electrolytic	.50
A6	25-230	2	2000 $\mu$ F electrolytic	1.90
A7	27-71	1	1 $\mu$ F Mylar*	1.30
A8	31-57	1	Trimmer, 2.7-20 pF	.65

\*DuPont Registered Trademark

KEY PART No.	PARTS No.	DESCRIPTION	PRICE Each	KEY PART No.	PARTS No.	DESCRIPTION	PRICE Each
<b>DIODES-TRANSISTORS*</b>				<b>HARDWARE</b>			
A9	58-57	1	1N716A, 12 V zener diode (violet-brown-blue-brown)	#4 Hardware			
A10	57-27	1	1N2071 diode	D1	250-285	2	4-40 x 1/4" screw
A10	57-65	4	1N4002 diode	D2	250-4	8	4-40 x 3/8" screw
A11	417-154	3	2N2389 transistor	D3	250-34	9	4-40 x 1/2" screw
A12	417-240	2	40673 transistor	D4	252-2	17	4-40 nut
A12	417-274	1	40673 transistor	D5	254-9	17	#4 lockwasher
<b>INTEGRATED CIRCUITS*</b>				#6 Hardware			
NOTE: The prefix and suffix letters may vary but the numbers must correspond to those listed below.							
B1	442-30	1	UA309K 5V regulator	E1	250-416	2	6-32 x 1/4" flat-head screw
B2	443-1	6	SN7400N quad NAND gate	E2	250-170	14	#6 x 1/4" sheet metal screw
B2	443-5	1	SN7473N dual J-K flip-flop	E3	250-89	5	6-32 x 3/8" screw
B2	443-7	6	SN7490N DCU	E4	250-206	4	6-32 x 1/16" screw
B3	443-13	6	SN7475N quad latch	E5	250-237	2	#6 x 3/8" sheet metal screw
B3	443-35	6	SN7441B or MC7441AP decoder/driver	E6	250-305	2	6-32 x 9/16" stud
B3	443-66	6	SN74192N Up/down counter	E7	250-40	2	6-32 x 1-1/2" screw
B2	443-70	1	SN74H103N J-K flip-flop	E8	252-3	11	6-32 nut
B2	443-71	2	SN74H00N NAND gate	E9	252-22	4	6-32 Speed Nut
*NOTE: Transistors and integrated circuits are marked for identification in one of the following four ways:				F1	254-1	15	#6 internal tooth lockwasher
1. Part number.				F2	254-6	11	#6 external tooth lockwasher
2. Transistor or integrated circuit type number.				<b>Other</b>			
3. Part number and type number.				F3	204-9	2	Angle bracket
4. Part number with type number other than the one listed.				F4	252-10	6	Push-on nut
<b>SHEET METAL PARTS</b>				F5	253-8	6	7/16" OD brass washer
C1	90-552-1	1	Cabinet	F6	253-84	4	3/8" OD flat washer
C1	200-628	1	Chassis	F7	255-2	9	Spacer
C2	203-882-1	1	Front panel	<b>SOCKETS-PLUG</b>			
C3	203-883-1	1	Rear panel	F8	434-42	3	Phono socket
C4	205-879	1	Circuit board shield	F9	434-201	6	Tube socket
C5	206-551-1	1	Light shield	F10	434-225	16	14-pin IC socket
C6	206-555	1	Top shield	F11	434-226	18	16-pin IC socket
C7	206-556	1	Bottom shield	F12	438-4	6	Phono plug
				F13	434-107	3	Phono socket, bushing mount**
				*Registered Trademark Tinneman Company			
				**For modification of receiving equipment.			



KEY PART No.	PARTS No.	DESCRIPTION	PRICE Each	KEY PART No.	PARTS No.	DESCRIPTION	PRICE Each
<b>WIRE AND CABLE</b>				<b>Miscellaneous (cont'd.)</b>			
89-23	1	Line cord	.75	391-34	1	Blue and white label	
340-3	1	Bare wire	.05/ft	H2 391-78	1	Nameplate	1.35
343-2	1	RG-58A/U coaxial cable (large)	.10/ft	H3 404-424	1	Crystal	5.70
343-12	1	RG-174 coaxial cable (small)	.10/ft	H4 411-264	6	Display tube (NL1220)	7.15
344-46	1	White wire	.10/ft	H5 412-11	1	NE-2 neon lamp (small)	.20
344-52	1	Red wire	.05/ft	H6 412-49	1	NE-51H neon lamp (large)	.40
344-56	1	Blue wire	.05/ft	H7 421-13	1	1/2-ampere 3 AG fuse	.15
<b>PLASTIC FIBER AND RUBBER PARTS</b>				H8 422-1	1	Fuse block	.25
G1 73-3	6	1/2" grommet	.10	H9 431-10	2	3-lug terminal strip	.10
G2 73-59	3	1/4" grommet	.10	H10 446-95	1	Window	1.70
G3 75-52	1	Insulator	.10	H11 475-10	3	Ferrite bead	.10
G4 75-71	1	Strain relief	.10	H12 490-5	1	Nut starter	.10
G5 207-4	2	Cable clamp	.10	H13 490-111	1	Integrated circuit puller	.10
G6 255-59	2	Tapered spacer	.10			Manual (See front cover for part number.)	2.00
G7 261-9	4	Rubber foot	.05	597-260	1	Parts Order Form	
<b>MISCELLANEOUS</b>				597-308	1	Kit Builders Guide	
G8 45-42	2	RF choke	.20			Solder (Additional 3' rolls of solder, #331-6, can be ordered for 15 cents each.)	
G8 45-76	1	RF choke	.20	<p>The above prices apply only on purchases from the Heath Company where shipment is to a U.S.A. destination. Add 10% (minimum 25 cents) to the price when ordering from a Heathkit Electronic Center to cover local sales tax, postage, and handling. Outside the U.S.A. parts and service are available from your local Heathkit source and will reflect additional transportation, taxes, duties, and rates of exchange.</p>			
54-298	1	Power transformer	5.00				
G9 80-48	1	DPDT rocker switch	.55				
74-6	1	Masking tape	.25				
G10 75-108	2	Fish paper	.10				
85-1445-1	1	Circuit board	9.55				
H1 205-778	1	1" steel blade	.10				
390-362	1	Fuse label	.10				



# STEP-BY-STEP ASSEMBLY

Before starting to assemble this kit, read the "Kit Builders Guide" for complete information on wiring, soldering, and step-by-step assembly procedures.

Resistors are designated by the color code and the resistance value. The symbol  $\Omega$  means ohms, and K or  $k\Omega$  indicates 1,000 ohms. Capacitors are designated by their value and type. The symbol  $\mu F$  means microfarad, and pF means picofarad. 1  $\mu F$  is equal to 1,000,000 pF.

At this time, lay aside the four .001  $\mu F$  (1.4 kV) disc capacitors so they will not be confused with others. These capacitors will be used when the primary circuit of the power transformer is wired.

Due to the small foil area around the circuit board holes and the small areas between foils, it is necessary to use the utmost care to prevent solder bridges between adjacent foil areas. Use a minimum amount of solder and do not heat components excessively. Diodes, transistors, and IC's can be damaged if subjected to excessive amounts of heat. Use a soldering iron rated at 15 to 25 watts. Its tip should be no wider than 1/16" at its widest dimension; a pyramid or chisel shaped tip is best. This type of soldering iron will make the kit easier to assemble with less chance of solder bridges occurring. Solder a part, or group of parts, only when instructed to do so.

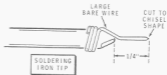


Figure 1-1

NOTE: If a small wattage, small-tip soldering iron is not available, proceed as follows: Be sure your soldering iron is cool. Then wrap the bare wire, supplied with this kit, tightly around the soldering iron tip as shown in Figure 1-1. Allow approximately 1/4" of wire to extend beyond the end of the soldering iron. Cut the wire end to a chisel shape as shown. You may have to replace this arrangement occasionally as the wire wrap will loosen after it has been heated for some time.

Most parts will be installed on the top (the side with the component outlines) of the circuit board, and the leads will be soldered to the foil (other) side. Solder the leads only to the foil side of the board unless specifically instructed to do otherwise. Due to the nature of the board, solder will be drawn through the circuit board plated-through holes to the top (component side) of the circuit board. This is normal.

## CIRCUIT BOARD ASSEMBLY

The steps performed in this Pictorial are in this area of the circuit board.

**START**



IDENTIFICATION  
DRAWING

**NOTE:** Only part of the circuit board is shown in the following Pictorials. An identification drawing at the top of each Pictorial shows the area of the circuit board to be assembled.

Position the circuit board as shown in the identification drawing. Then complete each step on Pictorial 1-1 through 1-11.

( ) 100 k $\Omega$  (brown-black-yellow).

( ) 100 k $\Omega$  (brown-black-yellow).

( ) 220 k $\Omega$  (red-red-yellow).

( ) 270  $\Omega$  (red-violet-brown).

( ) 100 k $\Omega$  (brown-black-yellow).

FOR GOOD SOLDERED CONNECTIONS, YOU MUST KEEP THE SOLDERING IRON TIP CLEAN. Wipe it often with a damp sponge or cloth.



( ) Solder the leads to the foil and cut off the excess lead lengths.

( ) 100 k $\Omega$  (brown-black-yellow).

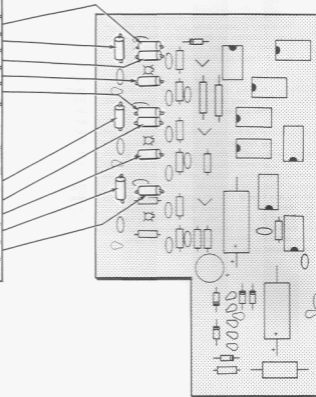
( ) 220 k $\Omega$  (red-red-yellow).

( ) 270  $\Omega$  (red-violet-brown).

( ) 100 k $\Omega$  (brown-black-yellow).

( ) 100 k $\Omega$  (brown-black-yellow).

( ) Solder the leads to the foil and cut off the excess lead lengths.



PICTORIAL 1-1

START



( ) 100  $\Omega$  (brown-black-brown).

( ) 1000  $\Omega$  (brown-black-red).

NOTE: When you install the precision resistors in the next two steps, position the body of the resistor 1/4" above the circuit board.

( ) 6838  $\Omega$ , 1%. The value is printed on the resistor.

( ) 1900  $\Omega$ , 1%. The value is printed on the resistor. Solder the leads to the foil on the component side of the circuit board.

( ) 100  $\Omega$  (brown-black-brown).

( ) 100 k $\Omega$  (brown-black-yellow).

( ) 1000  $\Omega$  (brown-black-red).

( ) 200  $\Omega$ , 5% (red-black-brown-gold).

( ) Solder all leads to the foil and cut off the excess lead lengths.

( ) 100  $\Omega$  (brown-black-brown).

( ) 220 k $\Omega$  (red-red-yellow).

( ) 270  $\Omega$  (red-violet-brown).

( ) 1000  $\Omega$  (brown-black-red).

( ) 330  $\Omega$  (orange-orange-brown).

( ) 100 k $\Omega$  (brown-black-yellow).

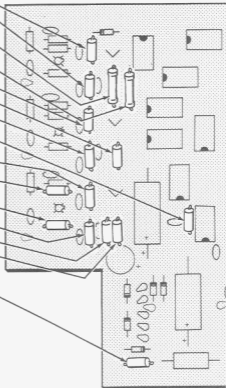
( ) 100 k $\Omega$  (brown-black-yellow).

( ) Solder all leads to the foil and cut off the excess lead lengths.

The steps performed in this Pictorial are in this area of the circuit board.



IDENTIFICATION  
DRAWING



PICTORIAL 1-2

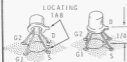
The steps performed in this Pictorial are in this area of the circuit board.

**START**



**NOTE:** To install transistors in the following three steps, match the tab on the transistor body to the tab outline printed on the circuit board. Then insert the four leads into the holes, push the transistor body down to within 1/4" of the circuit board. Solder each lead to the foil and cut off excess lead lengths.

- ( ) Transistor 40673 (#417-274) at Q1. Be sure you use the transistor with the #417-274 part number; there are other transistors of the same type number in this kit.



- ( ) Transistor 40673 (#417-240) at Q3.

- ( ) Transistor 40673 (#417-240) at Q5.

**NOTE:** DIODES MAY BE SUPPLIED IN ANY OF THE FOLLOWING SHAPES. ALWAYS POSITION THE BANDED END AS SHOWN ON THE CIRCUIT BOARD.



- ( ) 1N4002 diode (#57-65) at D3.

- ( ) 1N4002 diode (#57-65) at D1.

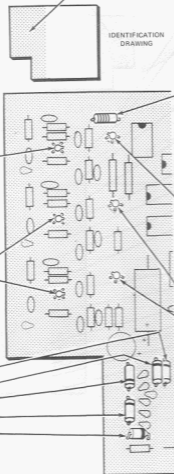
- ( ) 1N4002 diode (#57-65) at D2.

- ( ) 1N4002 diode (#57-65) at D4.

- ( ) 1N2071 diode (#57-27) at D5.

- ( ) Solder each lead to the foil and cut off excess lead lengths.

IDENTIFICATION DRAWING



- ( ) 1N716A zener diode (violet-brown-blue-brown, #56-57) at D6. Solder each lead to the foil and cut off the excess lead lengths.

**NOTE:** For the following three steps, position the tab on the transistor body near the E on the circuit board, as shown, and insert the leads into the holes. Position the transistor body 1/4" above the circuit board, solder each lead to the foil, and cut off excess lead lengths.

- ( ) 2N2369 transistor (#417-154) at Q2.



- ( ) 2N2369 transistor (#417-154) at Q4.

- ( ) 2N2369 transistor (#417-154) at Q6.

- ( ) Verify that all transistor leads and all diode leads have been soldered.

PICTORIAL 1-3

START



Before you install a disc capacitor, remove from its leads any excess body coating material which could protrude through the circuit board and cause a poor solder connection to the foil.

REMOVE COATING EVEN WITH BOTTOM OF CAPACITOR BODY.



( ) .001  $\mu$ F disc.

( ) .001  $\mu$ F disc.

( ) 47 pF disc.

( ) 47 pF disc.

( ) .001  $\mu$ F disc.

( ) .001  $\mu$ F disc.

( ) .001  $\mu$ F disc.

( ) 47 pF disc.

FOR GOOD SOLDERED CONNECTIONS, YOU MUST KEEP THE SOLDERING IRON TIP CLEAN.

WIPE IT OFTEN WITH A DAMP SPONGE OR CLOTH.



( ) Solder the leads to the foil and cut off the excess lead lengths.

( ) 47 pF disc.

( ) .001  $\mu$ F disc.

( ) .001  $\mu$ F disc.

( ) 47 pF disc.

( ) .001  $\mu$ F disc.

( ) .001  $\mu$ F disc.

( ) 47 pF disc.

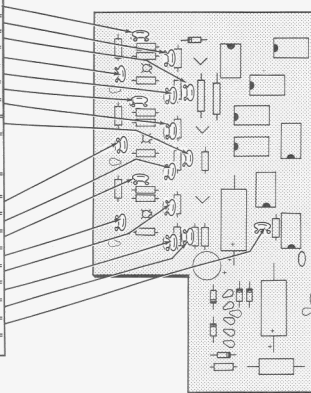
( ) .1  $\mu$ F disc.

( ) Solder the leads to the foil and cut off the excess lead lengths.

The steps performed in this Pictorial are in this area of the circuit board.



IDENTIFICATION DRAWING



PICTORIAL 1-4

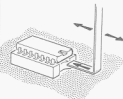
## START

**NOTE:** Both 14-pin and 16-pin dual-in-line IC's and sockets are used in this kit. Be very careful when you install the sockets, as it is possible to erroneously place a 14-pin socket in a 16-pin socket location. Match the cutout on one end of each socket to the similarly-shaped mark on the socket outline on the circuit board. Solder the pins of each socket to the foil as it is installed. Make sure all pins are in their holes before soldering.



( ) Install 14-pin dual-in-line sockets at IC10, 11, 24, 26, 32, 33, 34, and 35.

**NOTE:** An IC Lifter has been furnished to remove an IC from its socket if necessary.

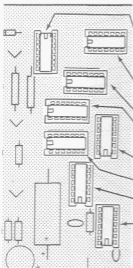


Push the shorter end of the lifter in between the IC and the socket and rock the longer portion back and forth. Be very careful as the IC pins are very easily bent.

## IDENTIFICATION DRAWING



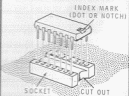
The steps performed in this Pictorial are in this area of the circuit board.



## CONTINUE

In the following steps, install IC's in the designated sockets. Be careful to match the index mark on each IC to the cutout in the end of its socket.

Before applying downward pressure to an IC, make sure each IC pin is centered in its proper socket aperture. Handle IC's with care as their pins are very easily bent.



( ) SN74H00N (#443-71) at IC24.

( ) SN74H00N (#443-71) at IC11.

( ) SN74H103N (#443-70) at IC25.

( ) SN7400N (#443-1) at IC10.

( ) SN7400N (#443-1) at IC34.

( ) SN7400N (#443-1) at IC33.

( ) SN7400N (#443-1) at IC32.

( ) SN7400N (#443-1) at IC35.

PICTORIAL 1-5

IDENTIFICATION  
DRAWING

The steps performed in this Pictorial are in this area of the circuit board.

**START**



**NOTE:** Solder the pins of each socket as it is installed.

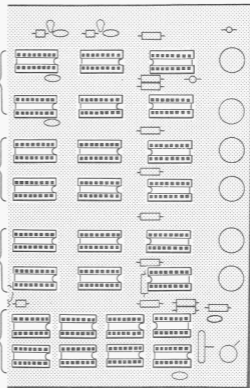
Note the position of the outcuts in the right-hand row of sockets.

( ) Six 16-pin sockets: IC12, 13, 18, 19, 26, and 27.

( ) Six 16-pin sockets: IC14, 15, 20, 21, 28, and 29.

( ) Six 16-pin sockets: IC16, 17, 22, 23, 30, and 31.

( ) Eight 14-pin sockets: IC2 through IC9. **IMPORTANT:** Note the position of the outcut for the socket at IC2.



PICTORIAL 1-6

IDENTIFICATION  
DRAWING

The steps performed in this Pictorial are in this area of the circuit board.

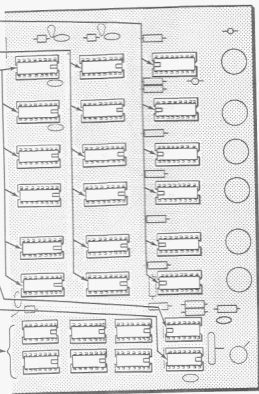
**START**



Install IC's as follows: Be sure to match the index mark on each IC to the socket cutout.

NOTE: The prefix and suffix letters in an IC type number will vary with the manufacturer, but the numbers must correspond. Be sure, however, to install the proper IC number at each location.

- ( ) Six SN7441B (#443-35) IC's: IC26, 27, 28, 29, 30, and 31.
- ( ) Six SN7475N (#443-13) IC's: IC18, 19, 20, 21, 22, and 23.
- ( ) Six SN74192 (#443-66) IC's: IC12, 13, 14, 15, 16, and 17.
- ( ) SN7400N (#443-1) at IC2. Note the position of the index mark.
- ( ) SN7473N (#443-5) at IC3.
- ( ) Six SN7490N (#443-7) IC's: IC4, 5, 6, 7, 8, and 9.



PICTORIAL 1-7

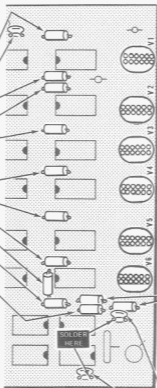


IDENTIFICATION  
DRAWING

The steps performed in this Pictorial are in this area of the circuit board.

START

- ( ) 47 k $\Omega$  (yellow-violet-orange).
- ( ) .1  $\mu$ F disc capacitor.
- ( ) 10 k $\Omega$  (brown-black-orange).
- ( ) 150 k $\Omega$  (brown-green-yellow).
- ( ) 10 k $\Omega$  (brown-black-orange).
- ( ) Solder all leads to the foil and cut off excess lead lengths.
- ( ) 10 k $\Omega$  (brown-black-orange).
- ( ) 10 k $\Omega$  (brown-black-orange).
- ( ) 10 k $\Omega$  (brown-black-orange).
- ( ) 33 k $\Omega$  (orange-orange-orange).
- ( ) 10 k $\Omega$  (brown-black-orange).
- ( ) 680  $\Omega$  (blue-gray-brown). If necessary, lean this resistor slightly away from the IC socket and push it down against the circuit board.
- ( ) Solder all leads to the foil and cut off excess lead lengths.



PICTORIAL 1-8

CONTINUE

- ( ) Remove the two pins shown from each of six tube sockets. Grasp each pin from the end with long-nose pliers. Then pull the pins straight out.



- ( ) Install tube sockets at V1, V2, V3, V4, V5, and V6. Solder each pin to the foil. Take care not to form any solder bridges between foils.
- ( ) 680  $\Omega$  (blue-gray-brown).
- ( ) 150  $\Omega$  (brown-green-brown).
- ( ) Solder all leads to the foil and cut off the excess lead lengths.

NOTE: As you install each of the following capacitors, solder the leads to the foil and cut off the excess lead lengths. Solder only the indicated lead of each capacitor on the component side of the circuit board. Solder the other lead to the foil side.

- ( ) .001  $\mu$ F disc.
- ( ) .05  $\mu$ F disc.

The steps performed in this Pictorial are in this area of the circuit board.



IDENTIFICATION  
DRAWING

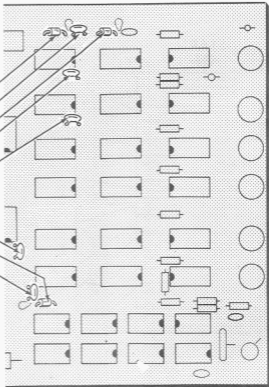
**START**



- ( ) Cut three 1" lengths of red hookup wire. Remove the insulation from each wire. Then push a bare wire through each of the three ferrite beads and bend down the wire ends as shown.



- ( ) Ferrite bead at FB1.  
 ( ) .1  $\mu$ F disc.  
 ( ) Ferrite bead at FB2.  
 ( ) .1  $\mu$ F disc.  
 ( ) .001  $\mu$ F disc.  
 ( ) .002  $\mu$ F disc.  
 ( ) Ferrite bead at FB3.  
 ( ) .1  $\mu$ F disc.  
 ( ) Solder all leads to the foil and cut off the excess lead lengths.



PICTORIAL 1-9



The steps performed in this Pictorial are in this area of the circuit board.



IDENTIFICATION  
DRAWING

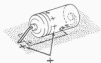
## START

**NOTE:** When you install electrolytic capacitors, match the + mark on the capacitor to the + mark on the circuit board.

- ( ) 100  $\mu$ F electrolytic capacitor. Mount the capacitor vertically. Match the + mark on the capacitor to the + mark on the board.



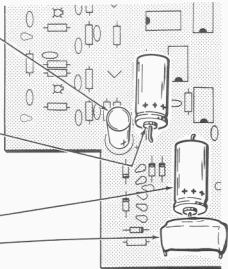
- ( ) 2000  $\mu$ F electrolytic. Be sure the lead does not touch the foil near pin 1 of IC33.



- ( ) 2000  $\mu$ F electrolytic.

- ( ) 1  $\mu$ F Mylar capacitor. Disregard any polarity markings on this capacitor.

- ( ) Solder each lead to the foil and cut off excess lead lengths.



PICTORIAL 1-10

The steps performed in this Pictorial are in these areas of the circuit board.



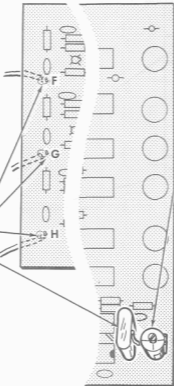
IDENTIFICATION  
DRAWING

START



NOTE: In the following three steps, insert each wire into its lettered hole from the foil side of the circuit board. Solder each wire to the foil. Cut off excess lead lengths on only the top of the circuit board.

- ( ) Cut three 2-1/2" lengths of red hookup wire. Remove 1/4" of insulation from both ends of each wire.
- ( ) 2-1/2" red hookup wire at hole F.
- ( ) 2-1/2" red hookup wire at hole G.
- ( ) 2-1/2" red hookup wire at hole H.
- ( ) Position the crystal (#404-426) 1/4" above the circuit board. Solder the leads to the foil and cut off the excess lead lengths.



CONTINUE



- ( ) Install the 2.7-20 pF trimmer.



- ( ) Turn the top plate of the trimmer capacitor so it covers half the lower plate.



NOTE: Disregard any unmarked unused holes in the circuit board.

Inspect the circuit board carefully for solder bridges. Be sure that all transistors, IC's, and diodes are installed correctly and at the proper locations. A magnifying glass will be helpful. Then lay the circuit board aside; it will be installed later.

FINISH

PICTORIAL 1-11

## CHASSIS ASSEMBLY

The illustrations in this section of the Manual are called Pictorials and Details. Pictorials show the overall operation for a group of assembly steps; Details are used in addition to the Pictorials to illustrate a single step. When you are directed to refer to a certain Pictorial "for the following steps," continue using that Pictorial until you are referred to another Pictorial for another group of steps.

Look at the "Chassis Photos" (Page 81) from time to time to see the actual positions of wires and components.

Lockwashers and nuts will be used with most screws when mounting parts. Consequently, the applicable steps will call out only the size and type of hardware used. For example, the phrase "Use 6-32 x 1/4" hardware" means to use 6-32 x 1/4" screws, one or more #6 lockwashers, and 6-32 nuts. Refer to the Details for the proper installation of hardware. Be sure to position the parts as shown in the Pictorials. Read the entire step before performing the operation and follow the instructions carefully.

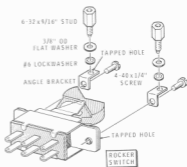
When a step directs you to "connect" an insulated wire, first prepare its ends by removing 1/4" of insulation.

A plastic nut starter has been provided with this kit. Use it to hold and start 6-32 and 4-40 nuts on screws. Refer to the "Kit Builders Guide" for more information.

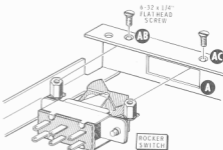
### CHASSIS PARTS MOUNTING

Refer to Pictorial 2-1 (fold-out from Page 23) for the following steps.

- |   |  |
|---|--|
| <p>( ) Refer to Detail 2-1A and mount two angle brackets on the rocker switch. Use 4-40 x 1/4" screws in the tapped holes of the switch mounting ears. Position the angle brackets as shown.</p> <p>( ) Refer to Detail 2-1A and install a 6-32 x 9/16" stud in the tapped hole of each angle bracket. Use a 3/8" OD flat washer and a #6 internal tooth lockwasher on each stud.</p> | <p>( ) Refer to Detail 2-1B and push the switch rocker into the rectangular hole in the front of the chassis at A. Then sight down through holes AB and AC to make sure that the tapped holes in the two studs are centered under holes AB and AC. If not, loosen the hardware and realign the angle brackets as necessary.</p> <p>( ) Secure the two studs to the chassis lip at AB and AC. Use 6-32 x 1/4" flat head screws.</p> |
|---|--|

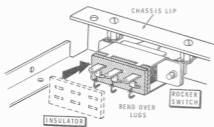


Detail 2-1A



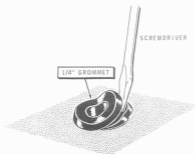
Detail 2-1B





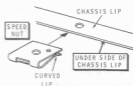
Detail 2-1C

- ( ) Refer to Detail 2-1C and push the insulator (#75-52) down over the six solder lugs of the rocker switch. Then bend the row of three switch lugs farthest from the chassis lip over against the insulator.
- ( ) Inspect the rocker to make sure it does not rub on the edges of the opening as it is operated. If it does, bend the angle brackets as necessary to provide clearance.



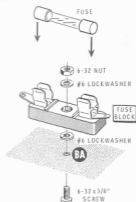
Detail 2-1D

- ( ) Refer to Detail 2-1D and install 1/4" grommets in chassis holes BE, BG, and BK.



Detail 2-1E

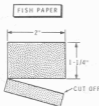
- ( ) Refer to Detail 2-1E and install Speed Nuts on the chassis lips at holes AA, AD, AE, and AF. Be sure the curved lip of each Speed Nut is on the inner side of the chassis lip.



Detail 2-1F

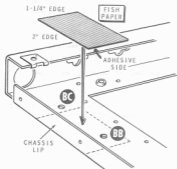
- ( ) Refer to Detail 2-1F and mount the fuse block on the chassis at BA. Use 6-32 x 3/8" hardware.
- ( ) Push the fuse into the fuse block.
- ( ) Remove the protective covering from the fuse label and press it into place in the location shown in the Pictorial.





Detail 2-1G

- ( ) Refer to Detail 2-1G and cut a 2" x 1-3/4" fish paper so it is 2" x 1-1/4".
- ( ) Remove and discard the white protective covering from the fish paper.

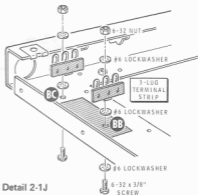


Detail 2-1H

- ( ) Refer to Detail 2-1H and place the adhesive side of the fish paper against the chassis so it covers hole BB, one of its 1-1/4" edges just touches the edge of hole BC, and the 2" edge is snug against the chassis lip.
- ( ) With a pointed instrument, make a hole through the fish paper at BB.

NOTE: In the following two steps, be sure you position the terminal strip mounting feet as shown in the Pictorial.

- ( ) Refer to Detail 2-1J and mount a 3-lug terminal strip at BB. Use 6-32 x 3/8" hardware. Start the nut on the screw with the plastic nut starter.



Detail 2-1J

- ( ) Similarly, mount a 3-lug terminal strip at BC. Note the placement of the lockwashers.

### CIRCUIT BOARD MOUNTING

Refer to Pictorial 2-2 (fold-out from this page) for the following steps.

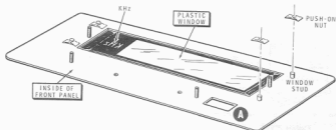
- ( ) From the bottom of the chassis, insert 4-40 x 1/2" screws into holes AK, AM, AR, AU, AX, AZ, BD, BH, and BL. Hold each screw in place with an inch of masking tape over the screw head (holes BD and BH are the two holes closest to the rear edge of the chassis).

- ( ) Position the chassis so the screw threads are up; then place a spacer and a #6 external tooth lockwasher on each screw.

- ( ) Hold the circuit board above the chassis and start a red wire into each of the chassis grommets. Then gently lower the circuit board so a screw enters each circuit board mounting hole.

- ( ) Place a #4 internal tooth lockwasher on each screw.

- ( ) Start a 4-40 nut on each screw. Then remove the tape from the screw heads and tighten the hardware. Do not overtighten; the circuit board can be damaged.
- NOTE: The foil at hole AR is a ground foil and it is all right for the lockwasher to touch it.



Detail 2-3A

## PANEL PREPARATION AND MOUNTING

Refer to Pictorial 2-3 for the following steps.

**NOTE:** When you apply the push-on nuts in the following step, be very careful and do not break the plastic studs on the back of the window. Twisting the nut on the stud may break the stud. Therefore, position the nuts exactly as shown in the Pictorial and push them straight down onto the studs. A nut driver may be used in applying the "push."

Refer to Detail 2-3A for the following three steps.

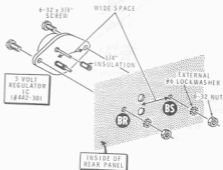
- ( ) Place the plastic window on a soft cloth on your work table with the four studs pointing up and the "kHz" marking to your left.
- ( ) Place the front panel (#203-882-1) on the four window studs with the rectangular opening at A, to your right. It is important that you have these two parts properly oriented. The window, once installed, cannot be remounted.
- ( ) Hold a push-on nut with its longer edge parallel with the longer edge of the panel, as shown, and push it straight down onto one of the four window studs. Push straight down until the nut is snug against the panel.
- ( ) In the same manner, install push-on nuts on the other three window studs. Position the nuts as shown.
- ( ) Refer to Pictorial 2-3 and mount the front panel on the chassis. Use #6 internal tooth lockwashers and 6-32 nuts at holes AN and AT. Do not tighten the nuts.

- ( ) Place the two studs of the nameplate in holes AP and AS (make sure the plate is positioned as shown). Secure them with push-on nuts. **NOTE:** If you have any difficulty, position the panel face down and place the edge of a magazine under the nameplate **ONLY** to support it while you apply the push-on nuts.

- ( ) Make sure the bottom of the front panel is aligned with the bottom of the chassis and tighten the nuts at AN and AT.

- ( ) Remove two 1/4" lengths of insulation from the white wire.

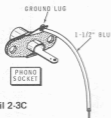
- ( ) Slide the 1/4" lengths of insulation onto each lead of the 5-volt regulator IC (#442-30).



Detail 2-3B

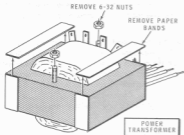
- ( ) Refer to Detail 2-3B and mount the IC at BR and BS on the outside of the rear panel. Use 6-32 x 3/8" hardware.





Detail 2-3C

- ( ) Prepare three 1-1/2" lengths of blue wire.
- ( ) Refer to Detail 2-3C and solder a 1-1/2" blue wire to the ground (shorter) lug of each of three phono sockets.
- ( ) Refer to Pictorial 2-3 and mount the rear panel on the chassis with 4-40 x 3/8" hardware at BN and BP. Tighten the hardware only finger tight.
- ( ) Mount the three phono sockets at holes C, D, and E with 4-40 x 3/8" hardware. Position the socket lugs as shown. Hold the sockets centered in their holes by plugging a phono plug in each socket until the hardware is tightened.
- ( ) Tighten the hardware at holes BP and BN. Then remove the phono plugs.



Detail 2-3D

Refer to Detail 2-3D for the following two steps.

- ( ) Remove the two paper bands from only the bottom of the power transformer if your transformer was furnished with these strips.
- ( ) Remove the two 6-32 nuts from the power transformer. Handle the transformer carefully so you do not loosen any of the core laminations and be careful not to break the ground wire when you remove the nuts.
- ( ) Mount the transformer on the top of the chassis at AG and AH. Be sure to position the leads toward hole AH. On each mounting screw, use a #6 internal tooth lockwasher and one of the 6-32 nuts just removed.

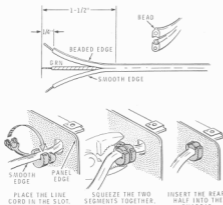
CHASSIS BOTTOM WIRING

Refer to Pictorial 2-4 (fold-out from Page 27) for the following steps.

NOTE: In the following steps, use the four .001  $\mu$ F (1.4 kV) disc capacitors set aside earlier.

- ( ) Refer to the inset drawing on the Pictorial and connect a .001  $\mu$ F disc capacitor between lugs 1 (NS) and 2 (NS) of terminal strip BC.
- ( ) Connect a .001  $\mu$ F disc capacitor between lugs 2 (NS) and 3 (NS) of terminal strip BC.
- ( ) Connect a .001  $\mu$ F disc capacitor between lugs 1 (NS) and 2 (NS) of terminal strip BB.
- ( ) Connect a .001  $\mu$ F disc capacitor between lugs 2 (S-2) and 3 (NS) of terminal strip BB.





Detail 2-4A

- ( ) Cut the leads of the two RF chokes (#45-42) to 5/8".
- ( ) Connect an RF choke (#45-42) from lug 1 of terminal strip BB (NS) to lug 1 of terminal strip BC (NS). Wrap the leads around the terminals on the side away from lug 2.
- ( ) Connect an RF choke from lug 3 of terminal strip BB (NS) to lug 3 of terminal strip BC (NS). Wrap the leads around the terminal on the side away from lug 2.

NOTE: As you connect each of the next four wires, wrap the wire ends around the lugs as shown in the Pictorial.

- ( ) Prepare a 1-1/2" white wire. Connect this wire from lug 3 of terminal strip BB (S-3) to lug 1 of the fuse block (S-1).
- ( ) Prepare three white wires of the following lengths. Twist the ends of each wire tightly together and melt a small amount of solder on each end.

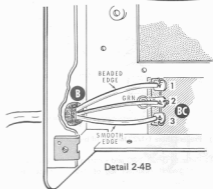
22"

11"

12-3/4"

NOTE: Route the following wires as shown in the Pictorial.

- ( ) Connect the 22" white wire from lug 1 of terminal strip BB (S-3) to lug 4 of the power transformer (NS).



- ( ) Connect the 11" white wire from lug 2 of the fuse block BA (S-1) to lug 3 of the switch (S-1).
- ( ) Connect the 12-3/4" white wire from lug 2 of the switch (S-1) to lug 1 of the power transformer (NS).

Refer to Detail 2-4A for the following steps:

- ( ) Separate the line cord conductors for a distance of 1-1/2" and, if not already done, remove 1/4" of insulation from the end of each wire. At the end of each conductor, twist the fine strands of wire tightly together and melt a small amount of solder on each end.
- ( ) Place the strain relief on the line cord 2" from the end. Then insert the free end of the line cord into hole B from the outside of the rear panel, with the beaded wire positioned as shown. Use pliers to compress the strain relief and insert it into hole B.

Refer to Detail 2-4B and connect the line cord conductors as follows:

- ( ) Connect the green wire to lug 2 of terminal strip BC. Wrap the bare end back over the top of the solder lug (S-3).
- ( ) Connect the line cord conductor with the smooth edge to lug 3 of terminal strip BC. Wrap the bare end of the wire around the edge of the lug away from lug 2 (S-3).
- ( ) Connect the line cord conductor with the beaded edge to lug 1 of terminal strip BC. Wrap the bare end of the wire around the edge of the lug away from lug 2 (S-3).

## TRANSFORMER PRIMARY WIRING

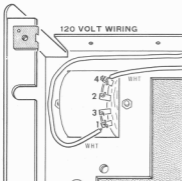
This Frequency Display can be wired to operate from either 120 VAC or 240 VAC, 50/60 Hz, line voltage. Therefore, two sets of steps are given for the wiring of the power transformer. Follow only the set of steps that agrees with the line voltage in your area.

All wires connected to lugs 1, 2, 3, and 4 of the power transformer must be wrapped around the sides of the solder lugs so the clearance to the bottom shield (to be installed later) will not be reduced.

In the following steps, prepare the required small bare wires by removing the insulation from 7/8" lengths of red wire.

### 120 VAC Wiring

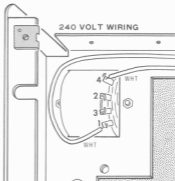
- ( ) Connect a 7/8" small bare wire from lug 1 (S-2) to lug 3 (S-1) of the power transformer.
- ( ) Connect a 7/8" small bare wire from lug 2 (S-1) to lug 4 (S-2) of the power transformer.



Detail 2-4C

### 240 VAC Wiring

- ( ) Connect a 7/8" small bare wire from lug 3 (S-1) to lug 2 (S-1) of the power transformer.
- ( ) Solder the white wires at lugs 1 and 4 of the power transformer.



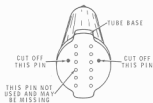
Detail 2-4D

NOTE: The blue and white label shows the model number of your kit. Refer to these numbers in any communications with the Heath Company.

- ( ) Refer to Detail 2-4E and install the blue and white identification label. Position the label within the outline on the rear panel so it exposes the correct wiring information and covers the incorrect information. Carefully peel away the backing paper. Then press the label into position. You will avoid smearing the numbers on the label if you will put the piece of waxed backing paper on top of the label and then rub on it instead of directly on the label.



Detail 2-4E



Detail 2-5A

## CHASSIS TOP WIRING

- ( ) Prepare the following wires:

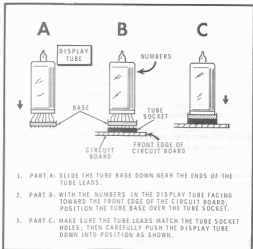
7" blue  
8" red  
10" red  
11" red

Refer to Pictorial 2-5 for the following steps.

- ( ) Connect the 7" blue wire from lug 1 of IC1 (S-1) to hole M on the circuit board (S-1).
- ( ) Connect the 8" red wire from lug 2 of IC1 (NS) to hole L in the circuit board (S-1). Use the indicated hole at location L.
- ( ) Connect the 10" red wire from lug 2 of IC1 (NS) to hole J in the circuit board (S-1).
- ( ) Connect the 11" red wire from lug 2 of IC1 (S-3) to hole K in the circuit board (S-1).

Connect the indicated leads of the power transformer to the circuit board as follows:

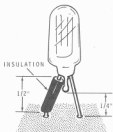
- ( ) Either blue to hole A (S-1).
- ( ) Blue-yellow to hole B (S-1).
- ( ) Other blue to hole C (S-1).
- ( ) Either red to hole D (S-1).
- ( ) Other red to hole E (S-1).
- ( ) Cut off any excess lead lengths.



Detail 2-5B

- PART A: SLIDE THE TUBE BASE DOWN NEAR THE ENDS OF THE TUBE LEADS.
- PART B: WITH THE NUMBERS IN THE DISPLAY TUBE FACING TOWARD THE FRONT EDGE OF THE CIRCUIT BOARD, POSITION THE TUBE BASE OVER THE TUBE SOCKET.
- PART C: MAKE SURE THE TUBE LEADS MATCH THE TUBE SOCKET HOLES, THEN CAREFULLY PUSH THE DISPLAY TUBE DOWN INTO POSITION AS SHOWN.

- ( ) Refer to Detail 2-5A and use diagonal cutters to cut off the two pins indicated on each of the six display tubes. Cut off the pins on the lower side of the tube base.
- ( ) Refer to Detail 2-5B and install the six display tubes on the circuit board at V1 through V6. Be sure the numbers inside the tubes are facing toward the window in the front panel.
- ( ) Cut a 1/2" length of red hookup wire. Remove the insulation in one piece and slide it onto one lead of an NE-51H neon lamp.
- ( ) Refer to Detail 2-5C and install the NE-51H (large) neon lamp at V7 with the insulated lead in the hole farthest from the edge of the circuit board. Position the lamp base 1/4" above the circuit board. Solder the leads to the foil and cut off excess lead lengths.
- ( ) Install the NE-2 neon lamp at V8. Position the lamp base 1/4" above the circuit board. Solder the leads to the foil and cut off excess lead lengths.

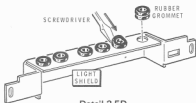


Detail 2-5C

- ( ) Refer to Detail 2-5D and install six rubber grommets in the light shield (#206-551-1).

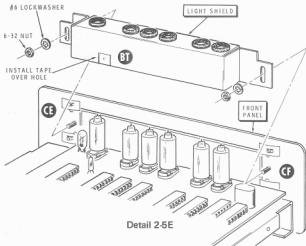
Install the two pieces of masking tape on the back of the light shield as follows:

- ( ) One piece of tape over hole BT as shown in Detail 2-5E.
- ( ) One piece of tape over rectangular hole BU as shown in the Pictorial 2-5.



Detail 2-5D

- ( ) Refer to Detail 2-5E and install the light shield on studs CE and CF on the back of the front panel. Use a #8 internal tooth lockwasher and a 6-32 nut on each stud. Be sure the pointed end of a display tube enters each grommet.
- ( ) Position lamp V7 behind opening BU in the light shield.
- ( ) Position lamp V8 behind hole BT in the back of the light shield. NOTE: The lamp will shine through this small hole to provide a decimal point for the display.
- ( ) Inspect the leads of V7 and V8 to make sure none of the leads are touching each other.



Detail 2-5E



## CABLE PREPARATION

Three cables will connect the Frequency Display to your receiver during the "Initial Tests" and later during normal operation. It is important that you carefully prepare the cables. Do not use excessive heat; it can damage the inner insulation of the coaxial cable.

Flat brass washers are used in the cable assembly to provide a convenient means of grasping the phono plugs when they are removed from their sockets.

- ( ) Cut the length of RG-58A/U (large) coaxial cable into three equal lengths.

Refer to Pictorial 2-6 and prepare both ends of one of the cable lengths as follows. The circled numbers refer to the numbered parts of the Pictorial.

- ( ) ①② Remove 1" of outer insulation from both ends of a coaxial cable. Be careful not to nick the braid with your knife.

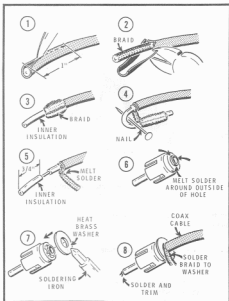
- ( ) ③ Push the shield braid back until it loosens and bulges out.

- ( ) ④ Make a hole in the shield braid, bend the cable sharply, and pull the inner insulation (and center conductor) out of the shield braid.

- ( ) ⑤ Pull the shield braid out into a tab at right angles to the cable. Use a minimum amount of heat and melt a small amount of solder onto the shield braid close to the inner insulation. Then remove 3/4" of inner insulation from the center conductor.

- ( ) ⑥ Melt a small amount of solder around the outside of the opening of the phono plug.

- ( ) ⑦ Hold the tip of the phono plug in a vise (or pliers with a rubber band around the handles) and place a 7/16" OD brass washer around the phono plug opening. Heat the washer with a soldering iron until the solder melts and the washer adheres to the phono plug.



PICTORIAL 2-6

- ( ) ⑧ Insert the coaxial cable into the phono plug. Solder the shield braid to the brass washer and the center conductor to the tip of the phono plug. Then cut off the excess lengths of shield braid and center conductor. File the cut end of the braid until it is smooth to the touch.

- ( ) Use an ohmmeter to make sure there is no short circuit between the center conductor and the cable shield braid.

- ( ) In like manner, install phono plugs and brass washers on both ends of the remaining two cables.



# INSTALLATION

The installation of the Frequency Display requires that your equipment (receiver or transceiver) furnishes three signals. These are the outputs of the HFO (high frequency oscillator), LMO/VFO (linear master oscillator/variable frequency oscillator), and BFO (beat frequency oscillator). This section of the manual presents the steps necessary to provide these three signals from Heath 5-band transceivers of the SB and HW (SB-100, HW-100, etc.), series and from amateur receivers of the SB series. No instructions for other makes of equipment are available.

Three unused phono sockets must be available on the rear panel of your receiving equipment. If they are not, they must be installed. Your kit contains three phono sockets (with mounting hardware) for this purpose. Figure 3-1 is the socket mounting detail. DO NOT drill any holes until you have carefully read the "Installation" instructions for your equipment.

Before deciding upon the location for the mounting holes, be sure no cabinet lips, interior mounted parts, or other interference will exist. Select the socket locations to retain rear panel symmetry. Use a center punch to mark the centers of the 1/4" holes to be drilled.

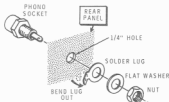


Figure 3-1

Figures 3-2 and 3-3 show two examples of where to locate additional phono sockets. Figure 3-2 shows an SB-102 transceiver. The original two spare phono sockets (spare A and spare B) are used. The ground terminal was moved and its original mounting hole was drilled out to provide a location for the third phono socket. Figure 3-3 shows where three phono sockets were added to an SB-301 receiver.

Install the required number of phono sockets on the rear panel of your receiver or transceiver. Then select the appropriate following section and perform the indicated steps to connect the three required signals to the sockets. Upon completion, proceed to "Initial Tests" on Page 39.

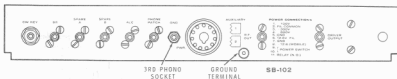


Figure 3-2

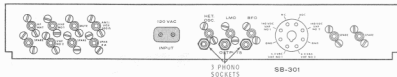


Figure 3-3

## TRANSCEIVERS

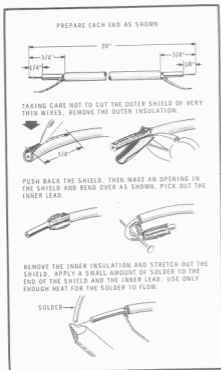


Figure 3-4

### BFO MODIFICATION (SB and HW Series)

Refer to Figure 3-4 for the following steps.

- ( ) Cut a 20" length of RG-174 coaxial cable and remove 3/4" outer insulation from each end.
- ( ) At each end of the coaxial cable, pull the inner insulation and center conductor from the outer shield.



Figure 3-5

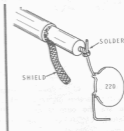
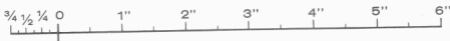


Figure 3-6

- ( ) Remove 1/4" of insulation from the center conductor and trim off any stray strands of wire from the shield braid.
- ( ) Refer to Figure 3-5 and cut the leads of a 220 pF capacitor to 1/4". Form the leads as shown.
- ( ) Refer to Figure 3-6 and connect one end of the cable center conductor to the 220 pF capacitor (S-1).

Refer to Figure 3-7 for the following steps:

- ( ) With the under side of the chassis positioned as shown, push the free end of the coaxial cable under the switch shaft and through grommet CB until about 3" remains over the modulator circuit board.
- ( ) Connect the foot of the 220 pF capacitor to the foil at point A (S-1).
- ( ) Connect the shield braid to the foil at Point B (S-1).
- ( ) Pull any excess cable through grommet CB, but do not place any strain on the capacitor or braid connections.
- ( ) Position the coaxial cable as shown and connect the center conductor at the free end to the center lug of an unused phono socket (S-1). Connect the braid to the ground lug of the same socket (S-1).
- ( ) On the outside of the rear panel, mark this socket "BFO."





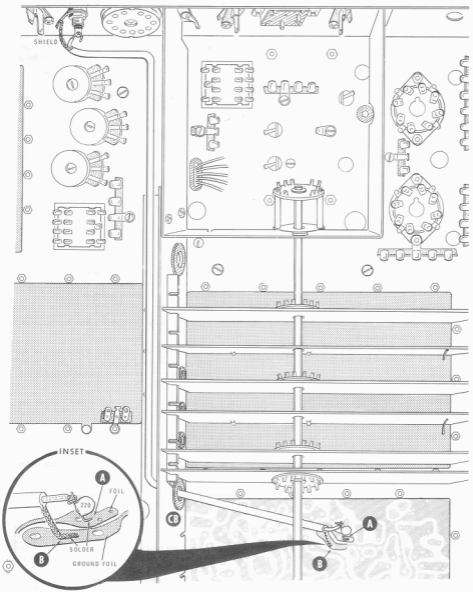


Figure 3-7

## HFO MODIFICATIONS (SB and HW Series)

Refer to Figure 3-8 for the following steps (HW-#series illustrated).

- ( ) Use a knife with a sharp point to break the foil near pin 8 of V19. A narrow strip of foil 1/32" to 1/16" wide should be cut and removed.
- ( ) Cut the leads of a 51  $\Omega$ , 5% resistor (green, brown, black, gold) resistor to 3/8" and form them as shown in the inset drawing.
- ( ) Solder the foot of one resistor lead to the foil at point C. Solder the other foot to the ground foil at point D.
- ( ) Cut a length of RG-174 coaxial cable (small) long enough to reach from point C in the preceding step to an unused phono socket, plus 1" (so the connections will not be under stress).
- ( ) Remove 3/4" of outer insulation from each end of the cable, pull the inner conductor out of the shield as before and remove 1/4" of insulation from the ends of the center conductor.
- ( ) At one end of the cable, connect the center conductor to point C (S-1) and the shield braid to point D (S-1).
- ( ) At the other end of the cable, connect the center conductor to the center lug of the selected phono socket (S-1). Connect the shield braid to the ground lug of the same socket (S-1).
- ( ) On the outside of the rear panel, mark this socket "HFO."

## LMO MODIFICATION (SB Series Only).

Refer to Figure 3-9 (fold-out from Page 35) for the following steps.

- ( ) Cut a length of RG-174 coaxial cable (small which will reach from foil pad H on the bandpass circuit board to an unused phono socket, plus 1".

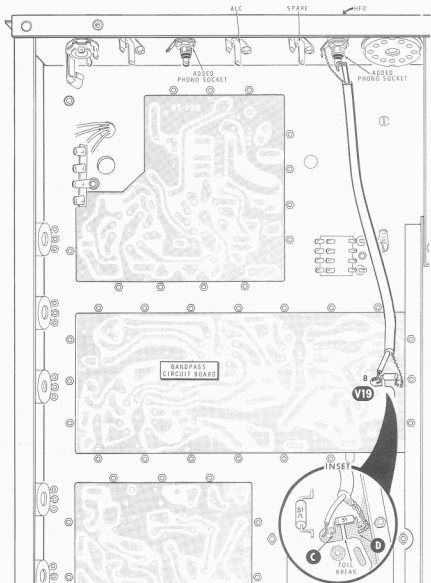
- ( ) Prepare the ends of the cable as before. See Figure 3-4.
- ( ) At one end of the cable, bend a small foot on the center conductor and solder it to foil pad H. Solder the shield braid of the cable to the hole in the foil at point E.
- ( ) At the free end of the coaxial cable, connect the center conductor to the center lug of the selected phono socket (S-1). Connect the shield braid to the ground lug of the same socket (S-1).
- ( ) On the outside of the rear panel, mark this socket "LMO."

## VFO MODIFICATION (HW Series 5-Band Transceivers Only)

Refer to Figure 3-10 (fold-out from Page 35) for the following steps.

- ( ) Cut a length of RG-174 coaxial cable (small) which will reach from foil pad G on the bandpass circuit board to an unused phono socket, plus 1".
- ( ) Prepare the ends of the cable as before. See Figure 3-4.
- ( ) At one end of the cable, bend a small foot on the center conductor and solder it to foil pad G. Solder the shield braid of the cable to the hole in the foil at J.
- ( ) At the free end of the coaxial cable, connect the center conductor to the center lug of the selected phono socket (S-1). Connect the shield braid to the ground lug of the same socket (S-1).
- ( ) On the outside of the rear panel, mark this socket "LMO."

**IMPORTANT:** AFTER you have completed the modification of your equipment for the Frequency Display, and BEFORE you start the "Initial Tests," refer to the manual for your equipment and perform the alignment instructions for the HFO (high frequency oscillator) circuits. Also, be sure your equipment is operating normally on all bands before starting the "Initial Tests."



**Figure 3-8**  
(HW-SERIES)





## CAUTION

Use extreme care during initial testing and all subsequent maintenance of this Frequency Display. While this device is designed for maximum safety, never lose respect for the high voltage present in this unit. Protect yourself always against lethal or severe electric shock.

HEATH COMPANY

# INITIAL TESTS

The following tests are to make sure your Frequency Display operates properly. The frequencies displayed at this time are approximately correct; the actual calibration will be accomplished later.

These tests cannot be performed unless your equipment has first been prepared according to the modification steps in the "Installation" section of this Manual.

Refer to Figure 4-1 (fold-out from Page 36).

- ( ) On the under side of the chassis, temporarily solder each of the three red wires coming from grommets to the longer solder lug of the corresponding phono socket.

**DANGER:** *Whenever the line cord is connected to an AC outlet, dangerous voltages will be present below the circuit board, even when the switch is in the OFF position. Except when an insulated tool is used, do not handle or work on this instrument when the covers are removed until the line cord has been disconnected. Refer to "High Voltage Areas" (fold-out from Page 36).*

In the following tests, you will use the numbers indicated on the display tubes to check this unit for proper operation. If you do not obtain the proper display in one of these steps, the areas and components most likely to cause your problem are listed after the step. If you are directed to check a component, apply the information in the "In Case of Difficulty" section to the component and the area around it as follows:

1. Use the "General Troubleshooting Information."
2. Refer to the "Troubleshooting Chart." If one of the "Symptoms" matches your difficulty, check the "Possible Causes" for that symptom.
3. Check the voltages against those given in the "Voltage Charts."

4. An oscilloscope is an extremely valuable tool for circuit analysis. Therefore, if a sensitive oscilloscope is available, use it for circuit tracing. Refer to the "Important Wave Shapes" on Page 54. Check the clock oscillator (IC2) for output, and follow the circuit path down through IC9. Also check for the presence of an input signal, starting at the socket on the rear panel of the modified unit.

- ( ) Connect the line cord plug of the Frequency Display to the AC source and turn the Display on. Lamps V7 and V8 (kHz and decimal point) should light, together with the five right-hand display tubes. Within two seconds the display tubes may flash once, after which each of the five tubes should display a "0." If this display is not obtained, refer to the "In Case of Difficulty" section of this Manual.
- ( ) Position lamp V7 so it illuminates the "kHz" in the window of the front panel.
- ( ) Position lamp V8 so it is directly behind the small hole in the light shield; this acts as a decimal point.

## NOTES:

1. In the following steps, the word "receiver" refers to your receiving equipment. The word "cable" refers to one of the three RG-58A/U cables prepared earlier.
2. The term "random" display is used to indicate rapidly changing numbers in the display.
3. A display of all zeros without a signal input has no significance as to whether the device is counting.

If there is a signal input and the display is all zeros, the device is not counting.

If there is a signal input and the display is random, the device is counting, but not correctly.

4. The displayed numbers are typed in this manual as they will appear on your Frequency Display.
5. Secure the proper display in each of the following steps before proceeding to the next.
  - ( ) Turn on your receiver and allow it to warm up for 10 minutes.
  - ( ) Turn the Band switch to 3.5.
  - ( ) Set the Mode switch at LSB.
  - ( ) Tune the receiver to zero beat its calibrator at 3700 kHz. Position the zero set line over the "0" on the circular dial. Then turn the calibrator off.

## NOTES:

1. In the following steps, be sure you make the cable connections on the receiver to the newly added or redesignated sockets ONLY.
  - ( ) Connect a cable from the receiver LMO output socket to the Frequency Display HFO socket. The display should be  $5\,300.0 \pm 5$  kHz and be stable. If this display is secured, proceed to the next step.
    - A. If the device does not count: Check the modification to your receiver; the connecting cable; Q1 and Q2; and IC's 10, 11, 12, 24, 25, and 32 through 35.
    - B. If there is a random count: Change the cable on the Frequency Display from the HFO to the LMO input. The display should now be  $94\,700.0 \pm 5$  kHz. If this display is secured, and is stable, there is difficulty with the HFO input circuit. Check Q1, Q2, and IC24.

If the display is still unstable, the problem is probably in the clock circuit. If you secure a voltage of approximately .5 VAC at pin 11 of IC8, the clock oscillator (IC2) and IC3 through IC8 are satisfactory.

- ( ) Remove the cable and reconnect it from the receiver BFO output socket to the Frequency Display HFO socket. The display should be  $3\,393.6 \pm 5$  kHz, and stable.

If this display is not secured, the difficulty is probably in the receiver modification to the BFO output, in the

cable connections, or the receiver MODE switch is in the wrong position.

- ( ) On the receiver, change the cable to the HFO output socket. The display should be  $12\,395.0 \pm 5$  kHz, and stable.

If this display is not secured, check the receiver modification for the HFO output, and the cable connections.

- ( ) Remove the cable.

NOTE: At this time, all three receiver outputs, and the HFO input of the Frequency Display, have been checked for satisfactory operation. The LMO and BFO inputs to the Frequency Display remain to be checked.

- ( ) Connect a cable between the receiver BFO output socket and to the Frequency Display BFO socket. The display should be  $96\,606.4 \pm 5$  kHz.

If the display is incorrect, move the cable from the BFO output socket to the LMO socket on the Frequency Display.

1. If the display is now correct; Q3, Q4, IC10, or associated circuitry is at fault.
2. If the display is still in error; check IC10, IC11, IC24, IC25, and IC's 32 through IC35.

- ( ) Leave the cable in the preceding step connected. Connect another cable from the receiver LMO output socket to the Frequency Display LMO socket. The display should be  $91\,304.0 \pm 5$  kHz.

If this display is not correct, check Q5 and Q6, IC10, and IC32 through IC35.

- ( ) Leave the two cables connected and connect a third cable from the receiver HFO output socket to the Frequency Display HFO socket. The display should be  $3\,700.0 \pm 10$  kHz, in which case the Frequency Display is operating properly.

If this display is not correct, check IC32 through IC35.

NOTE: The frequency displayed will probably not be accurate at this time. However, it is important that the frequency is approximately correct and that, except for the right-hand digit, the display is stable.

- ( ) Disconnect all cables and disconnect the Frequency Display line cord plug from the ac power source.

This completes the "Initial Tests." Turn to "Circuit Board Shield Installation."





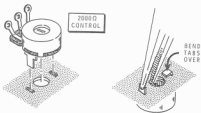
# CIRCUIT BOARD SHIELD INSTALLATION

Refer to Pictorial 4-1 (fold-out from Page 43) for the following steps.

- ( ) Unsolder the three red wires from the three phono sockets.
- ( ) Position the three red and the three blue wires so they point straight up from the circuit board.
- ( ) Refer to Detail 4-1A and mount three 2000  $\Omega$  controls on the circuit board shield at CL, CN, and CP. NOTE: It is possible to mount the controls on the wrong side of the shield. Be sure the large cutout in the corner of the shield is positioned as shown in the Pictorial. Place the controls so the three solder lugs point to the closer edge of the shield. Secure the controls by bending the lugs over with pliers or a screwdriver.

Refer to Detail 4-1B (fold-out from Page 43) for the following three steps:

- ( ) Place the circuit board shield against the bottom of the chassis so it covers the bottom of the circuit board. The three cutouts near the controls must clear the three grommets. Position this edge under the chassis lip first. Route the white wires out from under the shield at the side of the chassis and at the front panel edge.
- ( ) Secure the circuit board shield to the bottom of the chassis at AW, AY, BF and BJ. Use #6 x 1/4" sheet metal screws.
- ( ) Refer to Detail 4-1C and install plastic cable clamps at AJ and AL. Slip the clamps around the two white wires and secure each with a 3/8" OD flat washer and a #6 x 3/8" sheet metal screw.
- ( ) Connect the red wire coming from grommet BE to lug 2 of control CP (S-1).
- ( ) Connect the red wire coming from grommet BG to lug 2 of control CN (S-1).



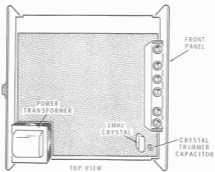
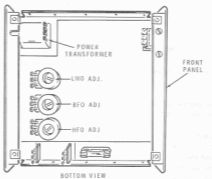
Detail 4-1A

- ( ) Connect the red wire coming from grommet BK to lug 2 of control CL (S-1).
- ( ) Prepare the following lengths of red wire:
 

One	1-1/2"
Two	1-1/4"
- ( ) Connect the 1-1/2" red wire from the longer lug of phono socket E (S-1) to lug 1 of control CL (S-1).
- ( ) Connect a 1-1/4" red wire from the longer lug of phono socket D (S-1) to lug 1 of control CN (S-1).
- ( ) Connect a 1-1/4" red wire from the longer lug of phono socket C (S-1) to lug 1 of control CP (S-1).

Connect the three blue wires coming from the phono sockets as follows:

- ( ) Blue wire from phono socket E to lug 3 of control CL (S-1).
- ( ) Blue wire from phono socket D to lug 3 of control CN (S-1).
- ( ) Blue wire from phono socket C to lug 3 of control CP (S-1).



PICTORIAL 4-2

# CALIBRATION

Refer to Pictorial 4-2 for the following steps.

- ( ) On the bottom of the circuit board shield, turn the three controls fully counterclockwise.
- ( ) Use the three previously prepared cables and connect the HFO, LMO (or VFO), and BFO receiver outputs to the corresponding input sockets on the rear panel of the Frequency Display.
- ( ) Plug the line cord of the Frequency Display into an AC receptacle.
- ( ) Turn on the Frequency Display and your receiver and let them warm up for at least 10 minutes.
- ( ) Set your receiver mode switch to USB, the band switch to 29.5, and the circular DIAL to 200.

NOTE: This calibration procedure adjusts the signal amplitude to the Frequency Display so it will not be overdriven.

A "stable" display is defined as one in which the display is unwavering at any receiver dial position. The right hand display tube may vary by one or two digits. If the display ends in 9, 1, or 0, this variation may also cause the fifth tube to vary by one digit (one kHz).

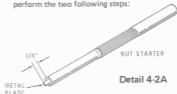
- ( ) Turn the LMO ADJUST control in a clockwise direction; the display may pass through an erratic area and then stabilize at  $94\ 700.0 \pm 5$  kHz. Then turn the control slightly more (about 1/16 of a turn).
- ( ) Turn the BFO ADJ clockwise in the same manner as in the preceding step until the display stabilizes at  $91\ 305.0 \pm 5$  kHz. Then turn the control slightly more.
- ( ) Turn the HFO ADJ clockwise until the display stabilizes at  $29\ 700.0 \pm 10$  kHz. Turn the control slightly more.

NOTE: The following step requires that an accurate calibration signal be received. In the U.S.A. or Canada use stations WWV (15.0000 MHz) or CHU (7.33500 MHz).

Otherwise, use a commercial station of known frequency accuracy. NOTE: The SB-301 receiver will receive WWV on 15 MHz, but the Frequency Display will not display the frequency as this receiver was designed so the HFO output is not switched to the rear panel socket when the band switch is in the 15 MHz position. This was done to prevent inadvertent transmission on the WWV frequency when transceiving.

If the above is impossible with your equipment, it will be necessary to adjust your calibrator (using the directions in your equipment manual) and then calibrate the Frequency Display against your calibrator.

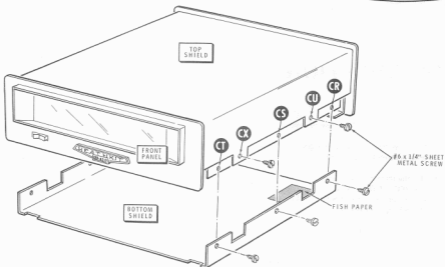
- ( ) Zero beat your receiver to a radio station whose frequency is known to be accurate. If the frequency of the station is correctly displayed, no further calibration is required. If the display is not correct, perform the two following steps:



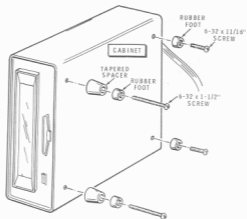
Detail 4-2A

- ( ) Refer to Detail 4-2A and use a pair of pliers to push the 1" steel blade into the smaller end of the nut starter until 1/8" remains exposed.
- ( ) Refer to Pictorial 4-2 and use the alignment tool to adjust the crystal trimmer capacitor so the display shows the correct frequency.
- ( ) Straighten the display tubes. Pass the large end of the nut starter through the grommet over each tube.
- ( ) Unplug the line cord of the Frequency Display.

This completes the "Calibration" of your Frequency Display. Proceed to "Final Assembly."



PICTORIAL 4-3



PICTORIAL 4-4

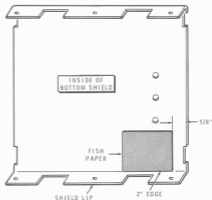
## FINAL ASSEMBLY

Refer to Pictorial 4-3 for the following steps.

- ( ) Refer to Detail 4-3A and install the remaining piece of fish paper on the bottom shield. Remove the white protective covering, position the paper as shown with the 2" edge along the chassis lip, and rub the paper into place.
- ( ) Attach the bottom shield to the chassis. Use six #6 x 1/4" sheet metal screws at CR, CS, and CT, and at the three corresponding holes on the other side of the chassis. Be sure the fish paper is positioned over terminal strips BB and BC (fold-out from Page 27).
- ( ) Attach the top shield to the chassis. Use four #6 x 1/4" sheet metal screws at CU, CX, and at the two holes on the other side of the chassis.
- ( ) Slide the Frequency Display into the cabinet so the four Speed Nuts on the corners of the chassis match the four holes in the bottom of the cabinet.

**NOTE:** At this time decide whether you want the cabinet of the Frequency Display to set level, or whether you wish the front of its cabinet elevated. Refer to Pictorial 4-4 and perform only one of the two following steps, depending upon how you want the cabinet positioned.

- ( ) If you want the cabinet to sit level, install a rubber foot at each corner of the cabinet. Use 6-32 x 11/16" screws.



Detail 4-3A

- ( ) If you wish the front of the cabinet elevated, install a rubber foot on each cabinet rear corner with a 6-32 x 11/16" screw. Install a tapered spacer and a rubber foot at each cabinet front corner with a 6-32 x 1-1/2" screw.

This completes the assembly of your Frequency Display. Proceed to "Operation."

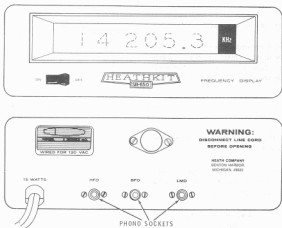


Figure 5-1

# OPERATION

Front and rear views of the Frequency Display are shown in Figure 5-1.

## OPERATING CONTROLS

The front panel switch turns the unit on and off. It is the only operating control.

## INTERCONNECTIONS

### SB-100, SB-101, SB-102, HW-100, and HW-101

The Frequency Display is connected to the three phono sockets on the rear panel as referred to in the "Installation" section of this Manual.

### SB-300, SB-301, and SB-303

Any existing connections between these Receivers and your other equipment will remain. The Frequency Display will be connected to the three phono sockets as referred to in the "Installation" section of the Manual.

## DISPLAY STABILITY

When the Display is first turned on, it may momentarily display a random number. The display will usually stabilize within two seconds and is then updated more than six times each second. Best display stability occurs after at least ten minutes warmup time.

Depending largely upon the exact frequency to which the receiver is tuned, the right hand display tube (hundreds of Hertz) may alternate between two numbers. This is normal. If the receiver is tuned very close to a frequency ending in 0

or 9 kHz, the second tube from the right will also vary as the right-hand display moves back and forth between the two numbers.

## ERRONEOUS READINGS

### SB-100, SB-101, SB-102, HW-100, and HW-101

When you operate in the CW mode, the Frequency Display will indicate the receiver frequency. The 1 kHz offset (BFO shift) will be indicated with the key down. During other operation; both the transmit and receive frequencies will be indicated.

### SB-300, SB-301, and SB-303

The BFO signal is not present when the MODE switch is in the AM position. The display will read high by the BFO frequency.

In the RTTY mode of the SB-301 and SB-303, the BFO signal is not present at the rear panel.

When these receivers are used with a transmitter in the transceive mode, the transmit frequency will be accurately displayed only if the same three oscillators are used in both transmit and receive modes.

## CAUTION

Do not position the Frequency Display on top of a transmitter, or other heat-producing equipment. The specified operating temperatures may be exceeded (see "Specifications"). If such a location is unavoidable, use a heat buffer such as a sheet of cork or asbestos under the Frequency Display, but do not block off the flow of air around the unit.

## IN CASE OF DIFFICULTY

This five-part section gives suggestions for locating and resolving difficulties.

The first part, "General Troubleshooting Information," deals with difficulties which exist upon completion of the assembly of your kit, and is primarily directed to soldering and assembly problems.

The second part consists of a "Troubleshooting Chart," which gives difficulties and likely causes.

The third part, "Voltage Checks," tells you how to check the power supply voltages, and includes Voltage Charts that show typical voltages at all IC's and transistors.

The fourth part, "Important Wave Shapes," contains charts with significant waveforms.

The "Customer Service" information inside the rear cover of the manual tells you what to do if you want to take advantage of the help available from the Heath Company.

If your check for soldering and assembly difficulties does not locate the problem, the difficulty is probably a component. Read the "Circuit Description" (Pages 67 through 73), refer to the Schematic Diagram (fold-out from Page 85), and use the signal path drawings (Pages 69 through 72).

## GENERAL TROUBLESHOOTING INFORMATION

1. Be sure the proper power was applied to the transformer primary; check the wiring.
2. Most problems result from poor connections and soldering. Use a reading glass and check all solder connections to be sure they are soldered as described in the "Soldering" section of the "Kit Builders Guide." Also check for bits of solder, wire ends, or other foreign matter which may be lodged in the wiring. Look for solder bridges between circuit board foils. Compare your foil pattern with the "X-Ray Views" on Page 81.
3. Check the continuity of the circuit board foils, including those places where a foil runs through a hole to connect a top foil and a bottom foil together. (Such a hole may also be used for mounting a component.) If you find an open foil, bridge it with a jumper wire. If necessary, drill a new small hole in the circuit board to pass the wire through the board. CAUTION: Never run a drill through any circuit board hole, as this will destroy any foil connection that goes through the hole.



NOTE: If a component lead (such as an IC terminal) is mounted in a hole through which the foil passes from the top to the bottom of the circuit board, place one of your probes on the component lead on top of the board. In this way, an open foil in the circuit board hole can be discovered.

4. Check the transistors and integrated circuits. See that the correct component is installed and that the leads are in the correct holes in the circuit board. Refer to the step-by-step Pictorials.
5. Check the values of the parts. Be sure the proper value has been wired into the circuit.
6. Press each integrated circuit firmly into its socket so that each pin will make a secure connection.

## SUBSTITUTION

Corresponding components of the circuitry for each tube can be interchanged with the components of another tube. IC's 12 through IC17 can be interchanged, for example.

If one display tube shows two digits simultaneously, interchange with one of the other tubes to determine if the tube or the circuit is faulty. If the circuit is faulty and there are no solder bridges on the associated foil, interchange the decoder/driver IC with one of the others. This method can be used with other single digit problems and can be extended to interchanging storage registers and up/down counter integrated circuits.

## COUNTING AND DISPLAY CIRCUITS (Figure 5-2)

A counting and display circuit consists of the up/down counter and the associated storage register, decoder/driver, and display tube. A high input impedance voltmeter can be used to check the logic states of only the storage registers, decoder/drivers, and display tubes. For these voltage checks, a "high" is 2.4 VDC or more, whereas a "low" is .4 VDC or less.

The up/down counters cannot be accurately checked with a voltmeter, as their outputs change rapidly with the count. The substitution method described above is one way to check them.

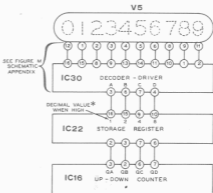


Figure 5-2

\*Add the values of the highs to determine the decimal equivalent. For example, if pins 16 and 9 of IC22 are high (pins 15 and 10 remain low), then the decimal equivalent is 5 (1+4=5). If only pin 10 is high, the decimal equivalent is 8. If all pins are low, the decimal equivalent is 0.

### EXAMPLE (Figure 5-2)

1. If tube V5 displays a "5" when you know a "3" should be seen (80 meter band), transpose IC16 (in this example) with one of the other up/down counters whose display is correct. If V5 still displays a "5," it is reasonable to assume the IC is operational. If the display changes to a "3," the IC is probably faulty, although the original IC should be inserted in its socket again to make sure.
2. If the display remains a "5," check the outputs of the storage register, IC22. If pins 16 and 9 are high and pins 15 and 10 are low, then the storage register is probably good (1+4=5).
3. The decoder/driver, IC30, should have pin 14 low to turn on the 5 in the display tube, and all other output pins should be high. If pin 9 should be low, which turns on the 3 in the display tube, but a 5 is displayed, then the fault is probably in the tube and it should be substituted with one of the others as confirmation.
4. If the foregoing checks are all indicative of a "5," then it is reasonable to assume that the difficulty lies ahead of the counting and display circuits.

## TROUBLESHOOTING CHART

SYMPTOM	POSSIBLE CAUSE
No lamps or display tubes light.	<ol style="list-style-type: none"> <li>1. Power supply faulty or no power to unit.</li> <li>2. No voltage on transformer primary.</li> <li>3. Transformer.</li> <li>4. Fuse blown.               <ol style="list-style-type: none"> <li>A. 5 volt line shorted.</li> <li>B. 12 volt line shorted.</li> <li>C. 170 volt line shorted.</li> </ol> </li> <li>5. No 170 volts, check D5.</li> </ol>
kHz and decimal lamps (V7 and V8) light; digits not lit.	<ol style="list-style-type: none"> <li>1. IC1.</li> <li>2. Rectifiers D1, D2, D3, or D4.</li> <li>3. 5 volts missing.</li> </ol>
Displays 00 000.0 all of the time (doesn't count).	<ol style="list-style-type: none"> <li>1. 12 volt missing.</li> <li>2. Clock not running: Meter needle should oscillate on 4volts (see voltage chart) for IC8 and IC9 when clock is running.               <ol style="list-style-type: none"> <li>A. Defective crystal.</li> <li>B. IC2 through IC9.</li> </ol> </li> <li>3. IC's 2, 9, 10, 11, 24, 25, or 34.               <ol style="list-style-type: none"> <li>A. IC2 reversed in socket, (In this case, display may have locked in on any number.)</li> </ol> </li> </ol>
One or more, but not all, display tubes show wrong number.	The associated readout circuitry; display tube, decoder/driver, storage, and up/down counter integrated circuits (which are physically in line behind each display tube).
One digit locked on one number; will not follow LMO tuning.	The associated readout circuitry; decoder/driver, storage, and up/down counter integrated circuits (which are physically in line behind each display tube).

SYMPTOM	POSSIBLE CAUSE
More than one digit lights in one display tube.	<ol style="list-style-type: none"> <li>1. Solder bridge across foil.</li> <li>2. Associated decoder/driver IC.</li> <li>3. Bent pin on readout tube.</li> <li>4. Display tube.</li> </ol>
Display remains at 99 999.9.	<ol style="list-style-type: none"> <li>1. IC25.</li> </ol>
Total display complete blur.	<ol style="list-style-type: none"> <li>1. IC35.</li> </ol>
Unit counts HFO, does not subtract LMO and BFO.	<ol style="list-style-type: none"> <li>1. IC9 or IC35.</li> </ol>
Unit counts erratic on 21 MHz band or higher.	<ol style="list-style-type: none"> <li>1. IC12, 24, or 25.</li> </ol>
Unit suddenly becomes erratic after it has been working properly.	<ol style="list-style-type: none"> <li>1. Ambient temperature too high. Observe the proper operating temperature specifications.</li> </ol>
Unit operates well on one or more 10-meter positions but is erratic on one or more of the other positions.	<ol style="list-style-type: none"> <li>1. HFO alignment in receiver incorrect. Align and readjust where necessary.</li> </ol>
Random display, changes only when turned on or OFF.	<ol style="list-style-type: none"> <li>1. IC32 or IC33.</li> <li>2. Clock not running: Meter needle should oscillate on <math>\mu</math>voltages (see voltage chart) for IC8 and IC9 when clock is running.                         <ol style="list-style-type: none"> <li>A. IC2 reversed in socket. (In this case display may have locked in on any number.)</li> <li>B. Defective crystal.</li> <li>C. IC2 through IC9.</li> </ol> </li> </ol>
Random display; frequency adjust control sensitive.	<ol style="list-style-type: none"> <li>1. IC2.</li> </ol>

## VOLTAGE CHECKS

### SUPPLY VOLTAGES

Three supply voltages (170, 5, and 12 volts) are required to operate this unit. If the decimal and kHz indicator lamps (V7 and V8) light, the 170 volt supply is functioning. If the six readout tubes light, the 5 volts must be present. If a signal at any of the inputs is counted, 12 volts is present at that input.

If these voltages are not present, measure the cathode of D5 for 170 volts, the cathode of D6 for 12 volts and the wire passing through each ferrite bead for 5 volts.

Measure the voltage at the Vcc pin of each IC on the shoulder of the pin where it enters the case.

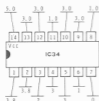
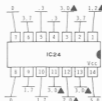
Typical supply and signal voltages (measured with a high impedance voltmeter) are given on the Voltage Charts. The ▲ symbol on the chart indicates the meter needle will oscillate (move quickly back and forth over a narrow range). The ● symbol indicates a voltage range from 2.5 to 90 volts.

If you interchange two IC's and the display does not change, assume neither IC is at fault. If the display changes, assume one or both IC's are at fault.

### VOLTAGE CHARTS



IDENTIFICATION  
DRAWING



## SUPPLY VOLTAGES

Three supply voltages (170, 5, and 12 volts) are required to operate this unit. If the decimal and kHz indicator lamps (V7 and V8) light, the 170 volt supply is functioning. If the six readout tubes light, the 5 volts must be present. If a signal at any of the inputs is counted, 12 volts is present at that input.

If these voltages are not present, measure the cathode of D5 for 170 volts, the cathode of D6 for 12 volts and the wire passing through each ferrite bead for 5 volts.

Measure  
shoulder

Typical  
impedance  
symbol C  
(move qu  
symbol i

If you in  
assume n  
one or bo

## VOLTAGE CHARTS



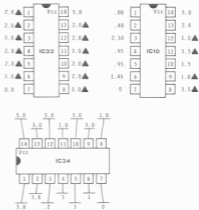
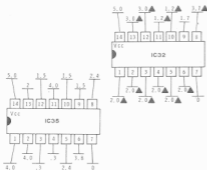
G1, 3, and 5



G4, and 6

IDENTIFICATION  
DRAWING

▲METER NEEDLE WILL OSCILLATE.



2.0 ▲ 1  
4.0 ▲ 2  
5.0 ▲ 3  
5.8 ▲ 4  
3.8 ▲ 5  
4.6 ▲ 6  
5.0 ▲ 7

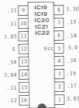
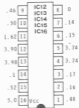
WITHOUT INPUTS CONNECTED:

● - CAN VARY FROM 2.5 TO 90 VOLTS DEPENDING ON MANUFACTURER.

\* - AC VOLTS.

▲ - METER NEEDLE WILL OSCILLATE

IDENTIFICATION  
DRAWING



## IMPORTANT WAVE SHAPES

This section consists of the significant wave shapes present at IC's other than those in the six counting chains. For information about the latter, see "Counting and Display Circuits" on Page 49.

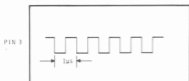
A 100 MHz bandwidth oscilloscope is desirable to properly reproduce these wave shapes. Those presented here were obtained by using a Tektronix Model 454 with a low

capacity X10 probe. The oscilloscope was set for 5 volts-per-division. Time is indicated in  $\mu\text{s}$  (microseconds) and ms (milliseconds).

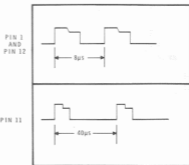
Filled-in waveforms indicate a sine-wave input signal being counted. If the signal input is removed, only the square waveform will remain.

NOTE: The lowest point of each of the following waveforms is 0 volts, whereas, the highest point is 2.4 to 5 volts.

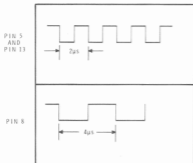
IC2



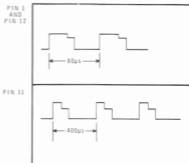
IC4



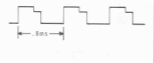
IC3



IC5



**IC6**

 PIN 1  
AND  
PIN 12


PIN 11

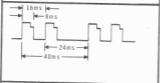

**IC8**

 PIN 1  
AND  
PIN 12

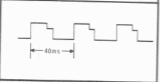
**IC7**

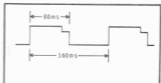
 PIN 1  
AND  
PIN 12


PIN 9



PIN 11

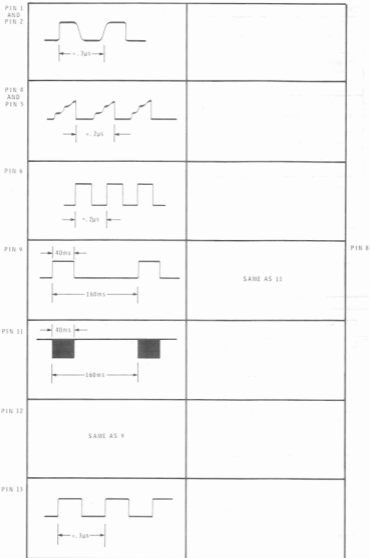

**IC9**

 PIN 1  
AND  
PIN 12


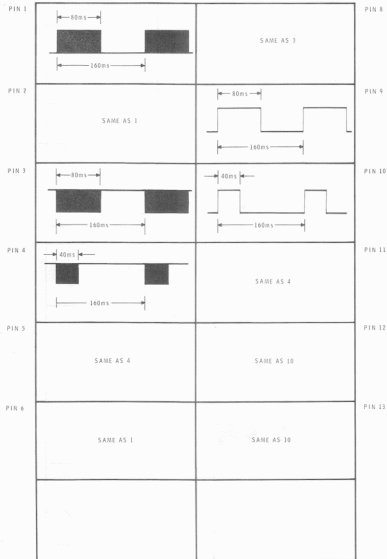


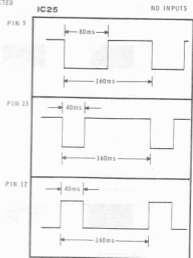
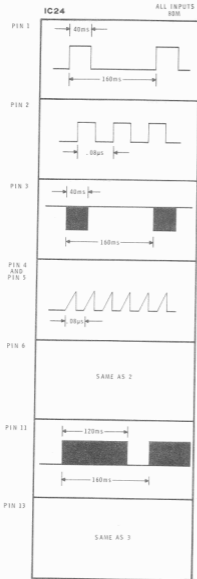
LMO CONNECTED  
BFO CONNECTED

IC10



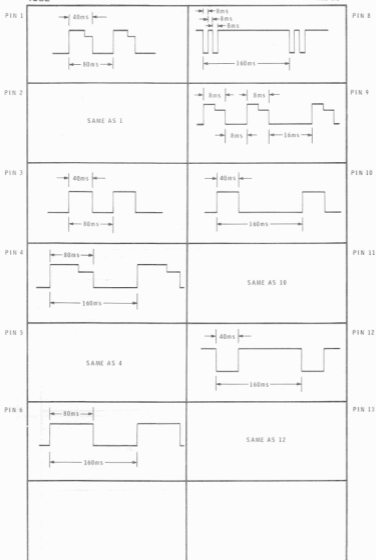
IC11

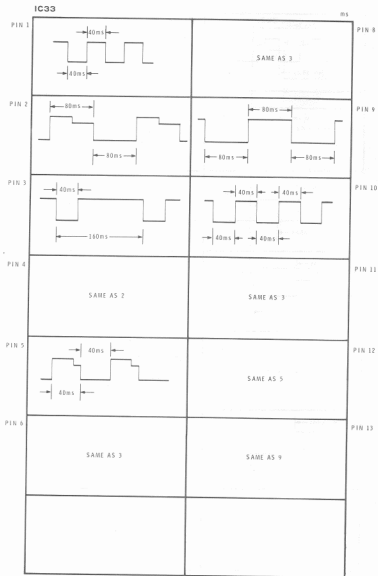
BAND: 3.5  
ALL INPUTS CONNECTED







IC32

ALL ms

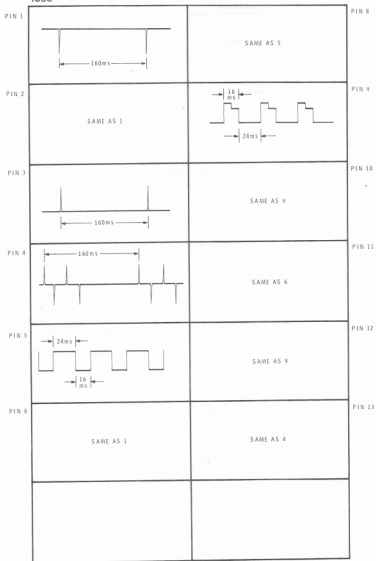




**IC34**

PIN 1		SAME AS 6	PIN 8
PIN 2	SAME AS 1	SAME AS 4	PIN 9
PIN 3		SAME AS 4	PIN 10
PIN 4		SAME AS 6	PIN 11
PIN 5	SAME AS 4	SAME AS 4	PIN 12
PIN 6		SAME AS 4	PIN 13

## IC35



# SPECIFICATIONS

Frequency range . . . . .	3 to 40 MHz.
Frequency display . . . . .	6 display tubes.
Maximum viewing distance . . . . .	30 feet.
Maximum input signal . . . . .	5 volts rms.
Accuracy . . . . .	Within 100 Hz $\pm 1$ count after 20 minute warm up.
Compute time . . . . .	160 milliseconds.
Input impedance . . . . .	2000 $\Omega$ .
Internally generated spurious frequencies . . . . .	< .25 $\mu$ V equivalent signal level.
Crystal (clock) frequency . . . . .	1 MHz.
Crystal aging rate . . . . .	<10 ppm/yr.
Ambient crystal stability . . . . .	<10 ppm from 10 to +65 degrees C.
Ambient operating temperature . . . . .	0 degrees to +40 degrees C.
Ambient storage temperature . . . . .	-55 degrees to +80 degrees C.
Power source . . . . .	105-125 or 210-250 VAC, 50/60 Hz, 15 watts.
Dimensions . . . . .	10" wide, 10-1/4" deep, 4" high.
Net weight . . . . .	4-1/2 lbs.

The Heath Company reserves the right to discontinue instruments and to change specifications at any time without incurring any obligation to incorporate new features in instruments previously sold.



# SPECIFICATIONS

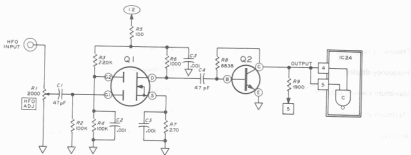


Figure 6-2

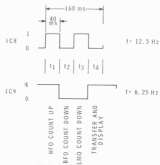


Figure 6-3

# CIRCUIT DESCRIPTION

While you read this description, refer to the Block Diagram (Figure 6-1 fold-out from Page 64) and the Schematic Diagram.

The Frequency Display receives signals from the three oscillators of a Heath amateur receiver or 5-band transceiver operating below 30 MHz. An up/down counter counts up the HFO (high frequency oscillator) frequency and then counts down to subtract the frequencies of the LMO (linear master oscillator) and the BFO (beat frequency oscillator). The result is the operating frequency, which is displayed by six illuminated tubes as kHz. An example of the operating frequency calculation for the 80 meter band follows:

	kHz
High frequency oscillator (count up)	12 395.0
Linear master oscillator (count down)	<u>-5 199.5</u>
	7 195.5
Beat frequency oscillator (count down)	<u>-3 383.6</u>
Operating frequency (display):	3 801.9

The frequency displayed is recalculated once every 160 milliseconds, or approximately six times each second. Each 160 milliseconds cycle is further divided into four parts of 40 milliseconds each. Three of these four parts are used by the counting cycles, and the fourth is used for the processing and display of the count.

In order to properly describe each counting cycle, the action is assumed to be "frozen" at a point in time. Connections not utilized in the function being described are not shown in the illustrations.

## INPUT CIRCUITS (Figure 6-2)

Except for the Q2 biasing, each of the three input circuits is identical, differing only in the gate to which the output is connected. Therefore, only the HFO (high frequency oscillator) input circuit will be described.

Control R1 adjusts the level of the input signal to Q1, a MOSFET which has a high input impedance to avoid loading the signal source. Other resistors and capacitors associated with Q1 are the usual biasing, loading, and bypass components. The input signal is amplified and coupled to Q2, which interconnects the output of Q1 to digital logic levels for the following circuits. R8 and R9 form a biasing network for Q2.

## CLOCK AND FREQUENCY DIVIDER

The clock oscillator is formed by IC2, and 1 MHz crystal Y1, and the associated parts. C31 is a trimmer capacitor to adjust the crystal to the exact frequency.

The 1 MHz output frequency of IC2 is divided by IC3 through IC9 (the clock frequency divider) as follows:

	FUNCTION	OUTPUT
	IC3 +4	250 kHz
	IC4 ÷10	25 kHz
1C5A	IC5 ÷10	2.5 kHz
1C5B	IC6 ÷10	250 Hz
	IC7 +10	25 Hz
	IC8 ÷2	12.5 Hz
	IC9 ÷2	6.25 Hz

*Handwritten notes:* 2.5 kHz, 2.5 kHz, 2.5 kHz, 1.25 kHz, 0.625 kHz, 16 sec

The four outputs of the clock frequency divider come from IC7, IC8, and IC9 as shown on the Schematic. These outputs provide the timing for the instrument.

Figure 6-3 shows the relationships between the output waveforms of IC8 and IC9 during one cycle of IC9, which is 160 milliseconds long (1 second ÷ 6.25 hertz). The four periods are each 40 milliseconds long and are designated t<sub>1</sub>, t<sub>2</sub>, t<sub>3</sub> and t<sub>4</sub>. The functions which occur during each time period are indicated.

NAND			
A	B	OUT	
0	0	1	
0	1	1	
1	0	1	
1	1	0	

Figure 6-4

## LOGIC CIRCUITRY

The gates used in this instrument are NAND type only. However, the gates used differ as to operating speed and frequency range.

Figure 6-4 is the truth table for a two-input NAND gate. The various combinations of logic levels at gate inputs A and B will result in the output logic levels shown in the OUT column. In this discussion, the terms "high" and "low" are often used to describe logic 1 and logic 0 levels, respectively.

In the first three lines of the truth table, whenever a gate has a low (logic 0) at any input, the output will always be a high (logic 1). This inhibits (closes) the gate as the output will always remain high, regardless of the logic level applied to the remaining input. The truth table also shows that if one input is held high, the gate is open. This is true because changing the logic level at the other input changes the logic level at the output. The truth table also shows that the logic level of the output is the complement (the output signal is inverted) of the input logic level. The gate is easily used as an ordinary inverter by applying the same logic level to both inputs, as evidenced in the first and last lines of the truth table.

Logic levels are shown at the inputs and outputs of most of the gates in this "Circuit Description." When levels are shown as "0/1", it means that the logic level is changing back and forth at the signal frequency.

The symbol  $\downarrow$  crossing the input line to an IC means that the IC will toggle (change output states) when the trailing edge of the input waveform appears, while  $\uparrow$  means that the device will toggle when the leading edge of the waveform appears.

## SEQUENCER AND MULTIPLEXER CIRCUITS

The function of these circuits is to process the output logic of the clock frequency divider so that the three input signals are selected in the correct sequence and routed through the proper channel to the up/down counter. Transistors Q2, Q4, and Q6 act as interfaces to translate the analog inputs into digital logic voltage levels. In each case, the gate following the transistor aids in the proper shaping of the signal waveform.

Figures 6-5, 6-7, and 6-8 are identical as to the devices shown. They differ as to the signal source, the signal path, and the control logic from the outputs of IC8 and IC9. The signal source is shown in a box in each Figure and the signal path is shown in heavy lines from the source box to the input of the up/down counter, IC12. Pin 5 of IC12 is the count-up input and pin 4 is the count-down input. Each figure shows the specific waveform relationship of IC8 and IC9 for the function illustrated.

The three oscillator inputs are always present, but all are inhibited by gates during  $t_4$ . Only the proper signal is permitted entry during the other three time periods. Figure 6-9 shows the logic levels during  $t_4$  when there is no counting.

The up/down counter has an upper frequency limitation and IC25 performs a divide-by-four function to bring the 10 meter band HFO signals within the counter's operating range.

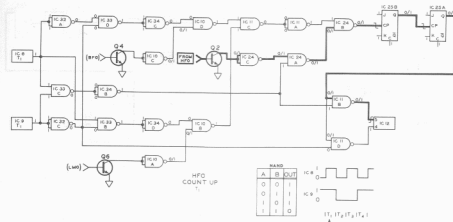


Figure 6-5

### HFO INPUT (Figure 6-5)

During the time the HFO input is counted, logic levels of time  $t_1$  apply and the HFO count-up function occurs.

The signal input is through Q2 and along the heavy lines to pin 5 of IC12, the count-up input of the up/down counter. The logic levels (see the truth table) from the outputs of IC8 and IC9 control the gates so only the signal from the HFO input is counted.

The signal from the BFO (Q4) is denied entry to the counter because IC10D is inhibited by a low at one of its inputs. Likewise, the LMO signal (Q6) is denied entry because IC10B is inhibited by a low.

The HFO signal can then be processed because one input of IC24A is held high by IC34B) and its output then alternates at the frequency of the signal at its other input. Gate IC24B is open because one input is held high by IC11A.

The flip-flops used are devices composed of interconnected gates and other components housed in an IC package. As connected, a negative-going signal at the input will cause a change in the logic level of the outputs. A positive-going input signal has no effect. Thus, each flip-flop divides its input frequency by two, as seen in Figure 6-6.

IC25, as it contains two flip-flops, performs a divide-by-four function. The signal path is then through IC11B (as one input is held high by IC34B) to pin 5 of IC12. The signal cannot pass through IC11D because it is inhibited by the low from IC32C.



Figure 6-6

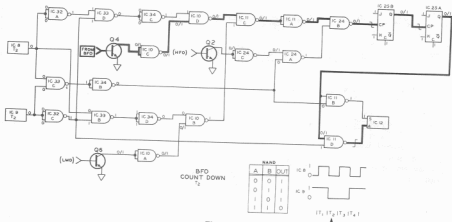


Figure 6-7

### BFO INPUT (Figure 6-7)

The BFO input is selected by the logic levels of IC8 and IC9 during time  $t_2$ . The signal path is through Q4 and along the heavy lines to IC25. Gate IC24A in the HFO signal path is now inhibited by a low at one of its inputs, as is IC10B in the LMO signal path.

### LMO INPUT (Figure 6-8)

During time  $t_3$ , IC8 and IC9 open the signal path from Q6, and inhibit gates IC24A and IC10D in the signal paths from Q2 and Q4. As in the case of the BFO input, the signal moves through IC11D to pin 4 of IC12, the count-down input of the counter.

The signal path from IC25 is through IC11D to pin 4 of IC12, the count-down input of the counter.

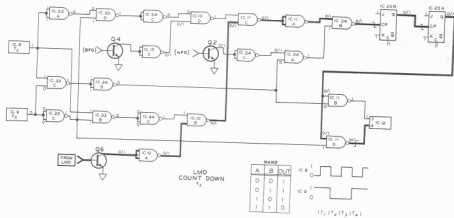


Figure 6-8



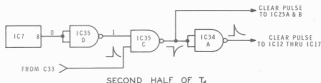


Figure 6-11

Figure 6-11 shows how the clear pulses are derived for the up/down counters and for IC25. These pulses return the counters and the flip-flop to zero, ready for the start of the next count.

During the second half of  $t_4$ , pin 8 of IC7 is low. The inversion to a high by IC35D holds IC35C open, so it passes and inverts the pulse from C33 (Figure 6-9). The negative-going pulse from IC35C is used as the clear pulse for IC25, whose Q outputs are thereby returned to 0, ready for the next counting cycle.

The negative pulse from IC35C is inverted by IC34A to a positive pulse which is used as the clear pulse to return IC12 through IC17 to zero.

## COUNTING AND DISPLAY

At the beginning of  $t_4$ , the transfer and storage period, the up/down count has been completed and is held in the counters. The count is in binary-coded decimal, or BCD, a numbering system using only two states (0 and 1). (The decimal system uses ten states, 0 through 9.) The binary system is convenient in digital circuits as its two states correspond to the two states of a switch — open or closed. A digit in the binary system (0 to 1) is called a "bit," and in most cases more bits are required to represent a quantity than is necessary in the decimal system. However, for logic circuits, the advantages of the binary system outweigh its disadvantages.

Each up/down counter has a 4-bit BCD output. For a few microseconds during  $t_4$ , the inputs to the storage register are opened by a transfer pulse, and the state of the completed binary count is transferred to the storage register, which holds the count until it receives another transfer pulse after the next count is completed. The principal reason for using a storage register is that the display is held steady until the next count has been completed. If the register was not used, the viewer would have to look at a blur of changing numbers during each count, and the display would actually remain constant for only a small fraction of a second.

The count held by the storage registers appears at the input of the decoder-driver, which decodes the binary count and turns on the proper number in the display tube.

## Up/Down Counters

The counters used are synchronous, 4-bit up/down counters. The four outputs of each are in the 1 2 4 8 or "natural" binary code. Figure J in the "Schematic Appendix" shows a block diagram of the counter, a schematic diagram, a partial waveform ladder chart, and a table showing the voltage levels which the device will recognize as a high or low. Note in the waveform chart that the outputs change state upon a low-to-high level transition of either input. Pin 5 is the count-up input and pin 4 is the count-down input. The direction (up or down) of counting is determined by the input to which the signal is fed while the other count input is held high.

## Storage Registers

The four binary outputs of an up/down counter are always present at the four inputs of a storage register, which is a 4-bit latch. The information present at each latch input is transferred to its Q output whenever the clock input is high. The output will follow the input data as long as the input remains high. When the input goes low, the state of the Q output is retained until the input again goes high. Therefore, when the positive-going transfer pulse arrives at the clock inputs from IC35A (Figure 6-9), the storage register inputs are opened for an instant. During this instant, the counter output states are transferred to the storage register where they are retained at the Q outputs until the next transfer pulse arrives.

## Decoder-Drivers

These devices receive the binary count present at the Q outputs of the storage registers and decode the count so one of the ten decoder-driver outputs is grounded. This results in the illumination of the correct number in a display tube. Figure M of the "Schematic Appendix" contains the information necessary to relate the binary input to the output logic levels required to turn on the proper display tube number.

## Display Tubes

The anode (pins 7 and 10) of each display tube is connected to the 170-volt DC supply line through a 10 k $\Omega$  current limiting resistor. The decimal point connections of each socket (pins 13 and 14) were cut off earlier. Each of the remaining 10 pins is connected to a tube cathode, each cathode being shaped as one of the numbers 0 through 9. When one of these cathodes is grounded (held low) by the decoder-driver, the gas immediately surrounding the cathode will ionize and the cathode will appear to glow.

The cathodes held high by the decoder/driver outputs will not glow.

Neon tubes V7 and V8 (kHz and decimal point illuminators) are turned on and off at the same time as the display tubes.

## POWER SUPPLY

The AC operated power supply can be wired to operate from either 120 volts or 240 volts.

One secondary winding of the power transformer is connected to diode D5 which acts as a half-wave rectifier for the 170-volt DC supply. This supply is filtered by C21 and R45.

The other secondary winding of the power transformer supplies two voltages:

The output of a bridge rectifier composed of diodes D1, D2, D3, and D4 is filtered by C19 and R29 and is regulated by zener diode D6 to furnish 12 VDC for the three MOSFET transistors Q1, Q3, and Q5.

Half of the winding in the preceding section is filtered by C17 and C18 and is processed by a voltage regulating circuit contained in IC1. Refer to Figure E of the "Schematic Appendix" for the schematic of this IC. This circuit furnishes a regulated 5 volts DC for the digital circuits and Q2, Q4, and Q6.

The three ferrite beads and capacitors C26, C27, and C28 on the three IC1 output lines are used to suppress vhf transients.



# SCHEMATIC APPENDIX

This appendix to the schematic diagram presents information concerning the display tubes and the solid state devices contained in your kit. Refer first to Figure A, below.

Then turn to the Figure number designated for each device for additional information, drawings, waveforms, and truth tables as appropriate.

COMPONENT DESIGNATION	PART NUMBER	QUANTITY	TYPE and RATING	FIGURE NUMBER
D1, 2, 3, 4	56-65	4	1N4002, 1A, 100 PIV	None
D5	57-27	1	1N2071, 1A, 600 PIV	None
D6	56-57	1	1N716A, 12V Zener, .4W	None
Q1	417-274	1	40673 (selected)	B
Q3, 5	417-240	3	40673	B
Q2, 4, 6	417-154	3	2N2369	C
V1 - V6	411-264	6	National Electronics NL1220 or Burroughs B-5859A	D
IC1	442-30	1	UA309K	E
IC2, 10, 32, 33, 34, 35	443-1	6	SN7400N	F
IC3	443-5	1	SN7473N	G
IC4, 5, 6, 7, 8, 9	443-7	6	SN7490N	H
IC11, 24	443-71	2	SN74H00N (High speed)	F
IC12, 13, 14, 15, 16, 17	443-66	6	SN74192N	J
IC18, 19, 20, 21, 22, 23	443-13	6	SN7475N	K
IC25	443-70	1	SN74H103N	L
IC26, 27, 28, 29, 30, 31	443-35	6	SN7441B	M

Figure A

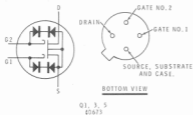


Figure B

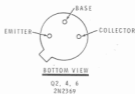
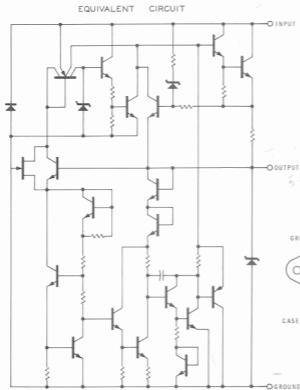


Figure C

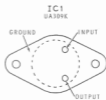


CIRCUIT BOARD EDGE	PIN	CONNECTION
7 • • 6	1	NUMERAL 1
	2	NUMERAL 2
8 • • 5	3	NUMERAL 3
	4	NUMERAL 4
14 • • 13	5	NUMERAL 5
9 • • 4	6	NUMERAL 6
10 • • 3	7*	ANODE
	8	NUMERAL 7
11 • • 2	9	NUMERAL 8
	10*	ANODE
12 • • 1	11	NUMERAL 9
	12	NUMERAL 0
BOTTOM VIEW	13	RT. DEC. PT.
	14	LFT. DEC. PT.

\* CONNECTED INTERNALLY

V1-V6  
NATIONAL ELECTRONICS NL1220 OR  
BURROUGHS B-5859A

Figure D



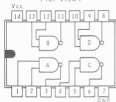
CASE IS CONNECTED TO GROUND.

BOTTOM VIEW

Figure E



DUAL-IN-LINE PACKAGE  
(TOP VIEW)



LOGIC LEVEL VOLTAGES

	MINIMUM	TYPICAL	MAXIMUM
GATE INPUT-HIGH	2V		0.8V
GATE INPUT-LOW		3.3V	
GATE OUTPUT-HIGH	2.4V		0.4V
GATE OUTPUT-LOW		-0.2V	

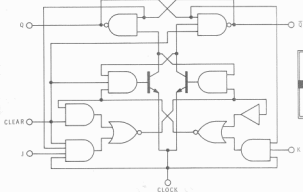
TRUTH TABLE  
(EACH GATE)

INPUTS		OUTPUT
A	B	
0	0	1
0	1	1
1	0	1
1	1	0

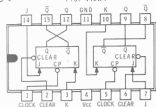
IC2, 10, 11, 24, 32, 33, 34, 35  
SN7400N, SN7400D

*NAND*  
**Figure F**

FUNCTIONAL BLOCK DIAGRAM  
(EACH FLIP-FLOP)



DUAL-IN-LINE PACKAGE  
(TOP VIEW)



LOGIC LEVEL VOLTAGES

	MINIMUM	TYPICAL	MAXIMUM
INPUT-HIGH	2V		0.8V
INPUT-LOW		3.5V	
OUTPUT-HIGH	2.4V		0.4V
OUTPUT-LOW		-0.2V	

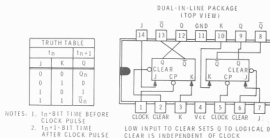
TRUTH TABLE  
(EACH FLIP-FLOP)

INPUTS			OUTPUT
J	K	Q	
0	0	Q	Q
0	1	0	0
1	0	1	1
1	1	Q	Q-bar

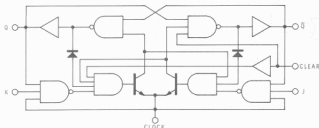
Q<sub>n</sub> STATE PRIOR TO  
CLOCK PULSE.

IC3  
SN7473N

**Figure G**



FUNCTIONAL BLOCK DIAGRAM  
(EACH FLIP-FLOP)

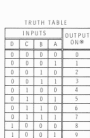


LOGIC LEVEL VOLTAGES

	MINIMUM	TYPICAL	MAXIMUM
INPUT-HIGH	2V		
INPUT-LOW			0.8V
OUTPUT-HIGH	2.4V	3.2V	
OUTPUT-LOW		0.25V	0.4V

IC25  
SN74H103N

Figure L



\*ALL OTHER OUTPUTS ARE OFF.

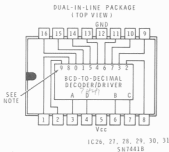


Figure M

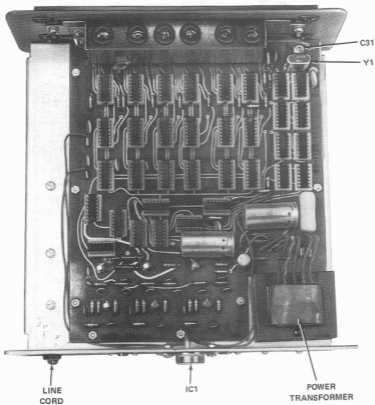
DECODER  
BCD to DECIMAL

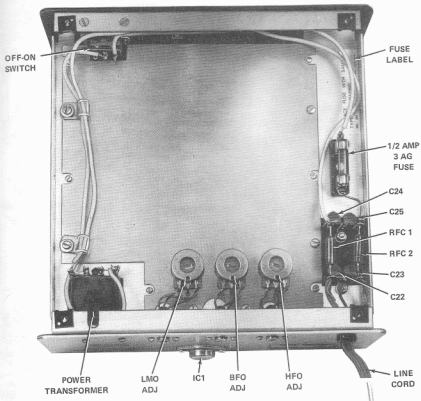
NOTE: THESE ARE THE DISPLAY TUBE NUMBERS WHICH WILL BE TURNED ON BY THE 10 DECODER-DRIVER OUTPUTS. THE ACTIVATED OUTPUT WILL BE "LOW" AND THE OTHER NINE OUTPUTS "HIGH". FOR EXAMPLE, IF THE NUMBER "7" IS ILLUMINATED IN THE DISPLAY TUBE, PIN 10 OF THE DECODER-DRIVER WILL BE "LOW" AND THE OTHER NINE OUTPUT PINS WILL BE "HIGH".

LOGIC LEVEL VOLTAGES

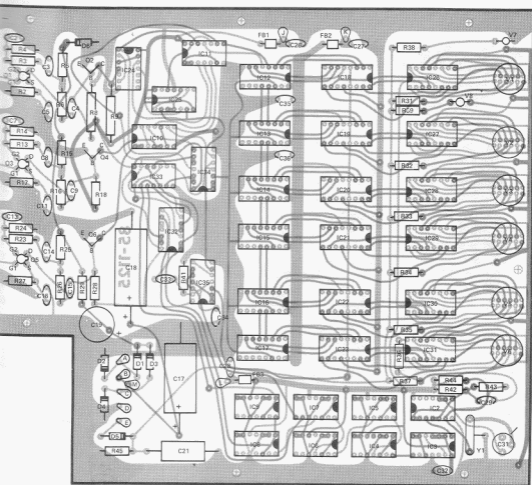
	MINIMUM	MAXIMUM
INPUT-HIGH	2V	
INPUT-LOW		0.8V
OUTPUT-HIGH	2.5V	90.0V

## CHASSIS PHOTOGRAPHS



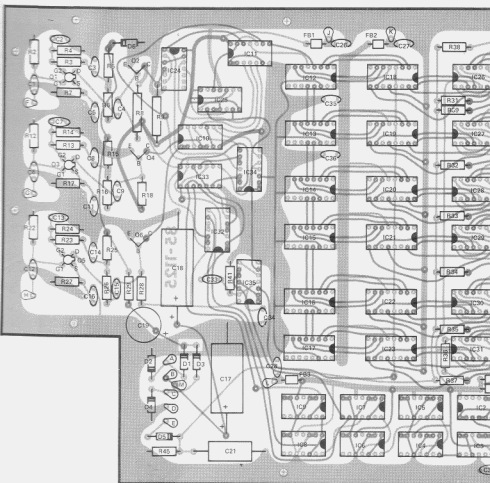


## CIRCUIT BOARD X-RAY VIEWS



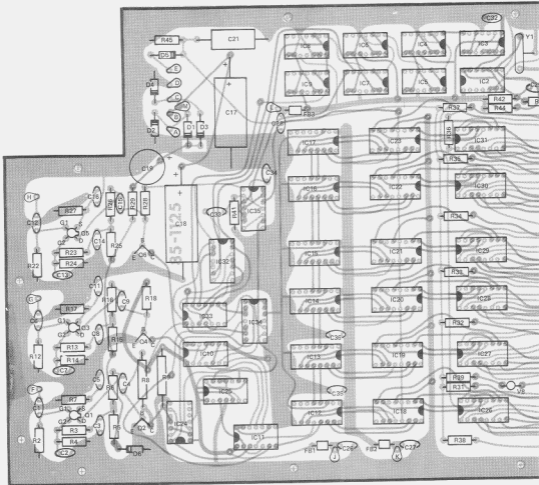
VIEWED FROM COMPONENT SIDE

## CIRCUIT BOARD X-RAY

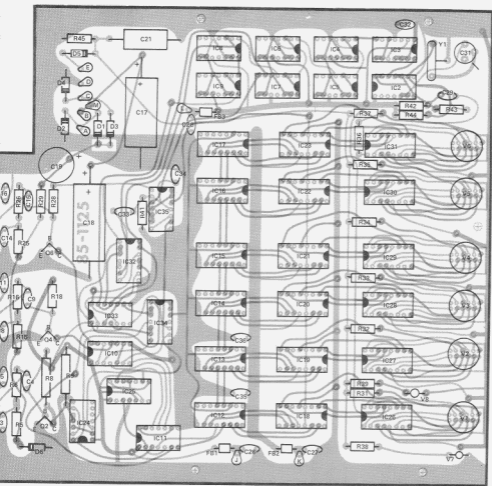


VIEWED FROM COMPONENT SIDE



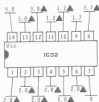
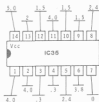


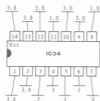
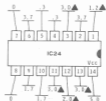
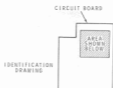
VIEWED FROM FOIL SIDE





▲ METER NEEDLE WILL OSCILLATE.





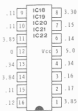
WITHOUT INPUTS CONNECTED.

● - CAN VARY FROM 2.5 TO 99 VOLTS DEPENDING ON MANUFACTURER.

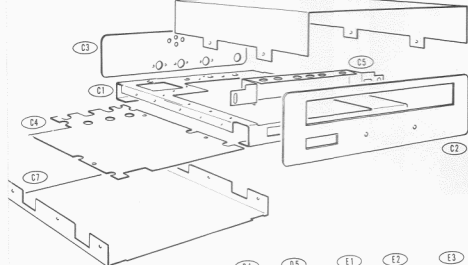
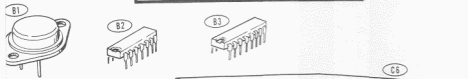
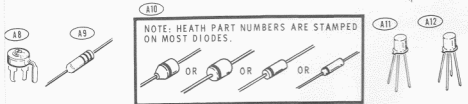
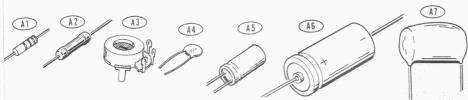
\* - AC VOLTS.

▲ - METER NEEDLE WILL OSCILLATE

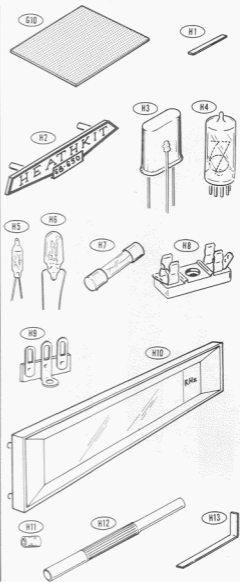
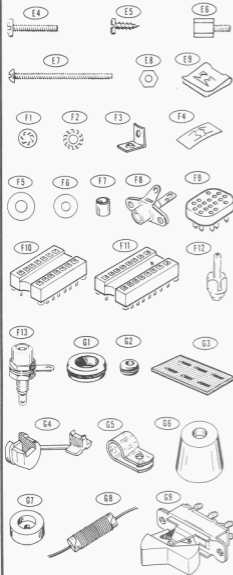
IDENTIFICATION  
DRAWING



# PARTS PICTOR



# TUTORIAL



The steps performed in this Pictorial are in these areas of the circuit board.



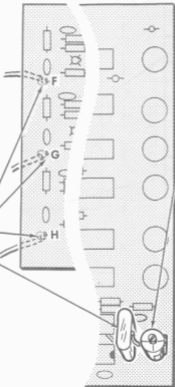
IDENTIFICATION  
DRAWING

START



**NOTE:** In the following three steps, insert each wire into its lettered hole from the foil side of the circuit board. Solder each wire to the foil. Cut off excess lead lengths on only the top of the circuit board.

- ( ) Cut three 2-1/2" lengths of red hookup wire. Remove 1/4" of insulation from both ends of each wire.
- ( ) 2-1/2" red hookup wire at hole F.
- ( ) 2-1/2" red hookup wire at hole G.
- ( ) 2-1/2" red hookup wire at hole H.
- ( ) Position the crystal (#404-424) 1/4" above the circuit board. Solder the leads to the foil and cut off the excess lead lengths.



CONTINUE



- ( ) Install the 2.7-20 pF trimmer.



- ( ) Turn the top plate of the trimmer capacitor so it covers half the lower plate.



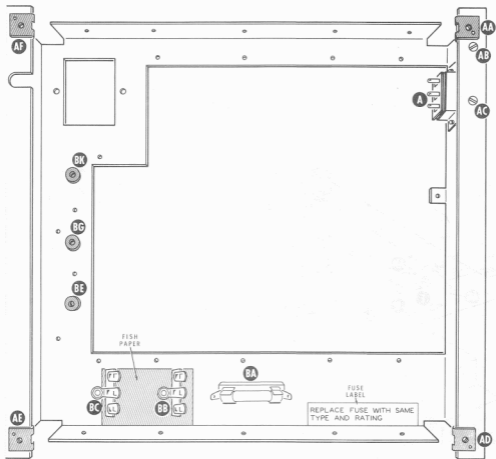
**NOTE:** Disregard any unmarked unused holes in the circuit board.

Inspect the circuit board carefully for solder bridges. Be sure that all transistors, IC's, and diodes are installed correctly and at the proper locations. A magnifying glass will be helpful. Then lay the circuit board aside; it will be installed later.

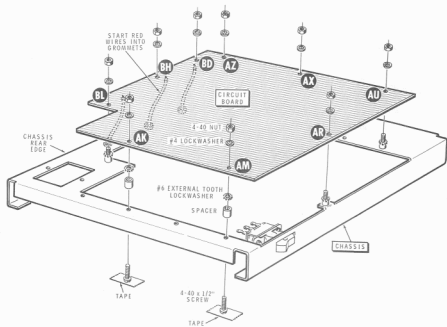
FINISH

PICTORIAL 1-11

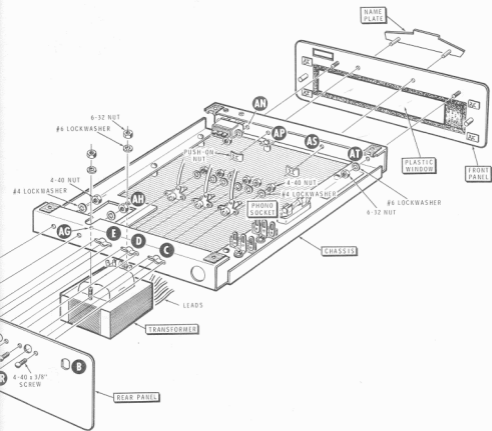




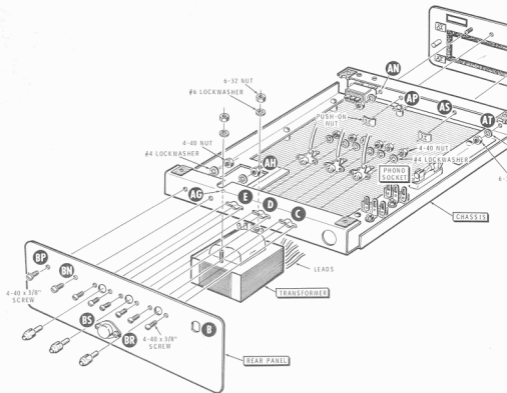
PICTORIAL 2-1



PICTORIAL 2-2

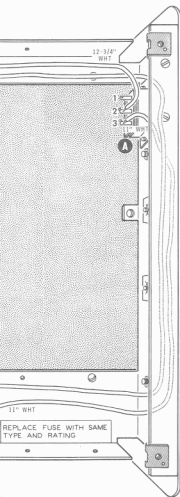


PICTORIAL 2-3

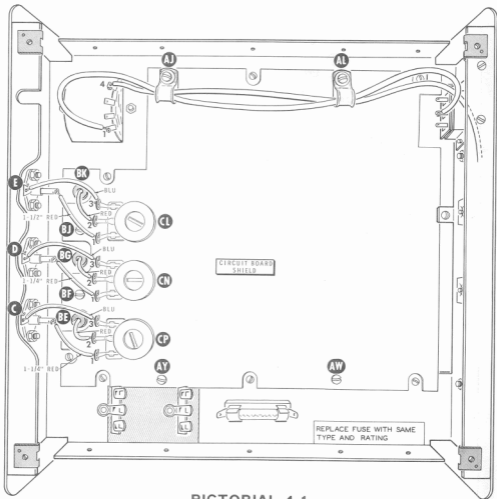


PICTORIAL 2-3



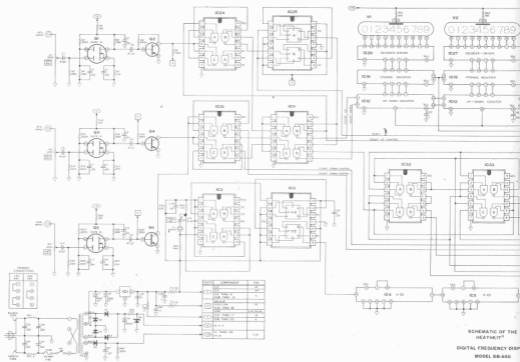




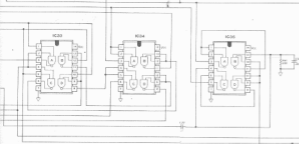
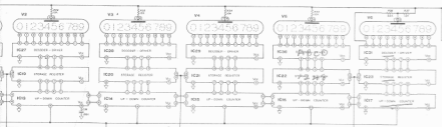


**PICTORIAL 4-1**





SCHEMATIC OF THE  
HEATHKIT®  
DIGITAL FREQUENCY DISP.  
MODEL 58-640



SEE GENERATOR APPENDIX STARTING ON PAGE 11.  
WEND.

1. RESISTORS ARE SHOWN IN OHMS UNLESS NOTED OTHERWISE.

2. CAPACITORS IN CIRCUIT ARE 100 P.F. UNLESS OTHERWISE NOTED.

3. EQUIPMENT IS EQUIPPED WITH INTERNAL PROTECTIVE CIRCUITS. SEE GENERATOR APPENDIX.

4. LF - CLOCK PULSE

5. -15V - 15V CONNECTION

6. SEE GENERATOR APPENDIX FOR CONNECTIONS TO GENERATOR.

7. SEE GENERATOR APPENDIX FOR CONNECTIONS TO TEST POINTS.

8. SEE GENERATOR APPENDIX FOR CONNECTIONS TO IDENTICAL LOGIC AND COMPONENT TESTS.

9. PERMIT READ.

10. REFER TO THE GENERATOR APPENDIX FOR ADDITIONAL INFORMATION ON THE SOLID STATE DISPLAY UNIT.

11. THIS SYMBOL INDICATES SIGNAL.



SCHEMATIC OF THE  
HEATHKIT®  
DIGITAL FREQUENCY DISPLAY  
MODEL 50-000



## CUSTOMER SERVICE

### REPLACEMENT PARTS

If you need a replacement part, please fill in the Parts Order Form that is furnished and mail it to the Heath Company. Or, if you write a letter, include the:

- Part number and description as shown in the Parts List.
- Model number and Series number from the blue and white label.
- Date of purchase.
- Nature of the defect.

Please do not return parts to the factory unless they are requested. Parts that are damaged through carelessness or misuse by the kit builder will not be replaced without cost, and will not be considered in warranty.

Parts are also available at the Heathkit Electronic Centers listed in your catalog. Be sure to provide the Heath part number. Bring in the original part when you request a warranty replacement from a Heathkit Electronic Center.

NOTE: Replacement parts are maintained specifically to repair Heathkit products. Parts sales for other reasons will be declined.

### TECHNICAL CONSULTATION

Need help with your kit? . . . Self-Service? . . . Construction? . . . Operation? . . . Call or write for assistance. You'll find our Technical Consultants eager to help with just about any technical problem except "customizing" for unique applications.

The effectiveness of our consultation service depends on the information you furnish. Be sure to tell us:

- The Model number and Series number from the blue and white label.
- The date of purchase.
- An exact description of the difficulty.
- Everything you have done in attempting to correct the problem.

Also include switch positions, connections to other units, operating procedures, voltage readings, and any other information you think might be helpful.

Please do not send parts for testing, unless this is specifically requested by our Consultants.

Hints: Telephone traffic is lightest at midweek. . . please be sure your Manual and notes are on hand when you call.

Heathkit Electronic Center facilities are also available for telephone or "walk-in" personal assistance.

### REPAIR SERVICE

Service facilities are available, if they are needed, to repair your completed kit. (Kits that have been modified, soldered with paste flux or acid core solder, cannot be accepted for repair.)

If it is convenient, personally deliver your kit to a Heathkit Electronic Center. For warranty parts replacement, supply a copy of the invoice or sales slip.

If you prefer to ship your kit to the factory, attach a letter containing the following information directly to the unit:

- Your name and address.
- Date of purchase.
- Copies of all correspondence relevant to the service of the kit.
- A brief description of the difficulty.
- Authorization to return your kit C.O.D. for the service and shipping charges. (This will reduce the possibility of delay.)

Check the equipment to see that all screws and parts are secured. (Do not include any wooden cabinets or color television picture tubes, as these are easily damaged in shipment.) Place the equipment in a strong carton with at least THREE INCHES of resilient packing material (shredded paper, excelsior, etc.) on all sides. Use additional packing material where there are protrusions (control sticks, large knobs, etc.). If the unit weighs over 15 lbs., place this carton in another one with 3/4" of packing material between the two.

Seal the carton with reinforced gummed tape, tie it with a strong cord, and mark it "Fragile" on at least two sides. Remember, the carrier will not accept liability for shipping damage if the unit is insufficiently packed. Ship by prepaid express, United Parcel Service, or insured Parcel Post to:

Heath Company  
Service Department  
Benton Harbor, Michigan 49022

HEATH

Schlumberger

HEATH COMPANY • BENTON HARBOR, MICHIGAN  
**THE WORLD'S FINEST ELECTRONIC EQUIPMENT IN KIT FORM**

LITHO IN U.S.A.